



~ Accessory Installation

HYUNDAI Genuine Accessories

Vehicle Model Sonata
 Model Year 2015 ~
 Part No. C2062 ADU00/P0

Accessory Mirror, Auto-dim w/
 HL4, BL, & Comp
 Difficulty (B)

Note: Difficulty stated above reflects the minimum level of expertise required to install the accessory.
 (A) Customer (B) Dealer Technician (C) Master Technician

This product is only applicable to vehicles equipped with Blue Link.

Instructional Symbols / Definitions

	Denotes warnings that may lead to serious physical injury or vehicle damage.		Denotes quality processes to be checked prior to moving to the next step.	Denotes safety equipment required to be used such as a mask, safety glasses, gloves, and hearing protection.	
	Denotes cautions to be taken to avoid physical injury or electronic component damage.		Denotes specific tools that are necessary to complete the step.		
	Denotes cautions to be taken to avoid vehicle and component damage.		Denotes instructional steps necessary to complete the process.		

Basic Required Hand Tools

Ratchet	10mm Socket	T20 Torx Socket
T20 Torx Driver	Torque Wrench	

FMVSS 110 Compliance Information

Part Number:
 C2062 ADU00
 C2062 ADUP0

1.31 lbs
 0.593 kg
 (Gross Weight)

All dealers must determine if the weight they have added in the form of all options or accessories, when added to the weight of all Port/Dealer Installed options or accessories, exceeds the lesser of 1.5% of GVWR or 100 lbs. If the additional weight does exceed the lesser of the indicated thresholds, a "Load Carrying Capacity Reduced" label must be installed. A black fine point, indelible marker must be used to write by hand onto the label, the reduced carrying capacity in kilograms or pounds, which is the total weight of all added options and accessories.
 Load Label Part Number:
 NP070 - 09003

Notes to the Installer:

- 1) Read the entire installation instructions prior to beginning the installation of this accessory.
- 2) Make sure the vehicle is completely clean before the accessory is installed.
- 3) Ensure the vehicle is properly protected in the area(s) that the accessory is to be installed.
- 4) To prevent vehicle damage, never place tools on top of painted surfaces, seats, dash pad, console, or floor/carpet/mats.
- 5) Always wear appropriate safety gear to include gloves and safety glasses when required.
- 6) Do NOT accidentally start vehicle while performing function checks at the end of the install.



550-0624 Rev. AAA

Revision Date
 03/03/2014

HYUNDAI Genuine Accessories

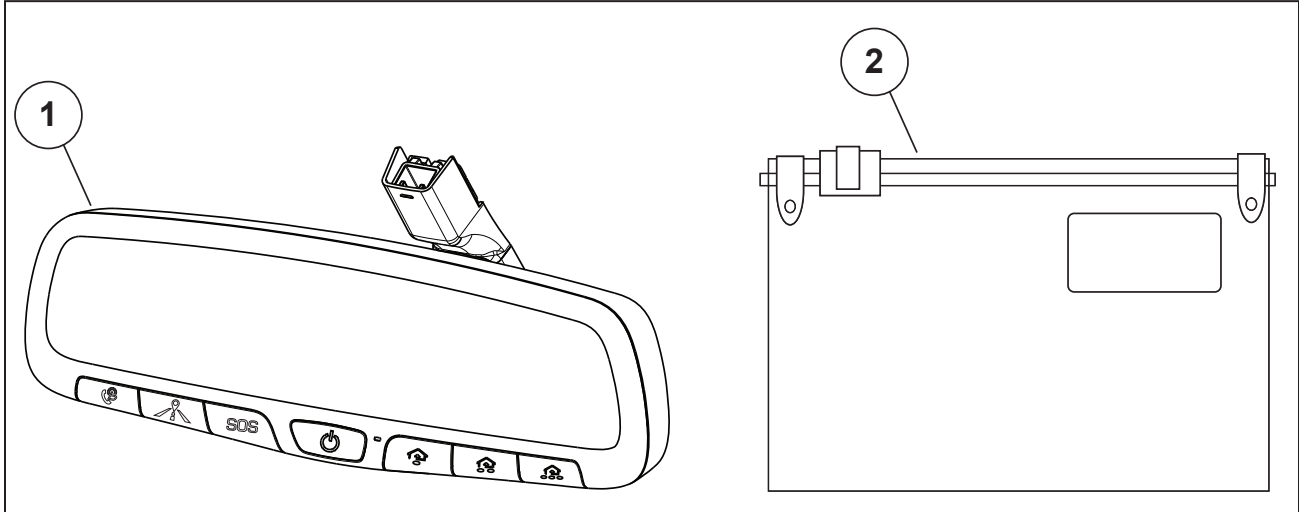

No.	Qty.	Description	No.	Qty.	Description
1	1	Auto-dimming Mirror w/ Blue Link, Compass, & HomeLink			
2	1	Hardware Kit			

Hardware Kit Review

A	
1	Installation Instructions

B	
1	Quick Reference Guide

Hardware Kit Total
2

WIRE CODES

Wires are either solid color or striped wires. The first color in the description indicates the base color of the wire, the second indicates the color of the stripe (or tracer).

Example:

Solid Color Wire

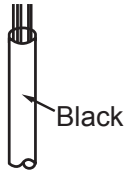

Black wire

Striped Wire

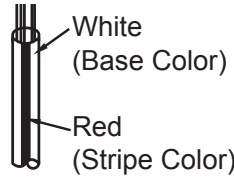

White w/ Red Tracer wire

CONNECTOR DIAGRAMS

Connector diagrams show the harness side view. **The pin numbers are from the harness side view.**

Example:

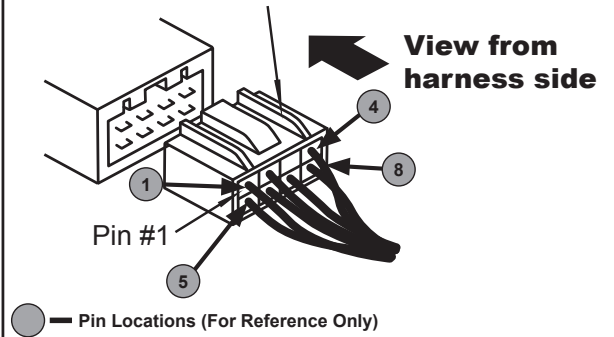

DISCONNECTING CONNECTORS

When disconnecting the wires, grasp the connectors, not the wires.

Example:

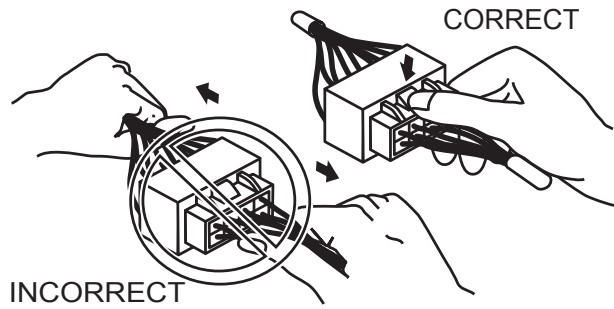

LOCKING CONNECTORS

When locking connectors, listen for a click, indicating they are securely locked.

Example:

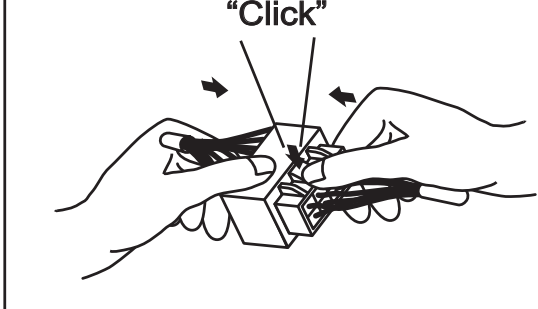

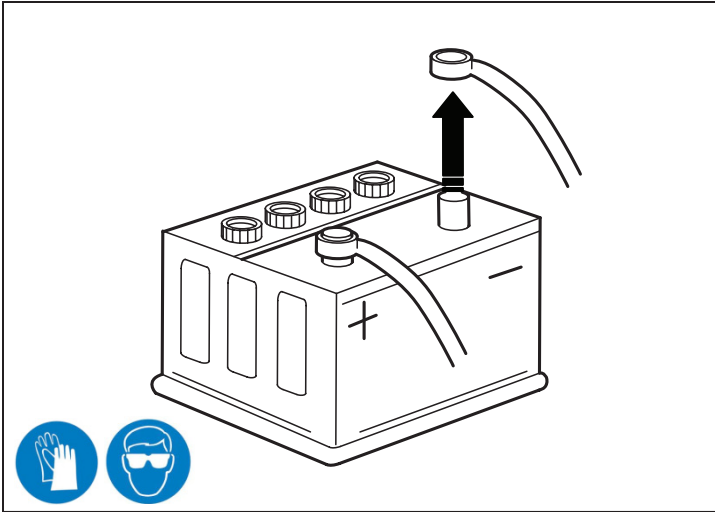

Ratchet & 10mm Socket 1

- 1. Ensure the correct part is being installed.** Verify part number on the order request with the part number on the kit box label.
2. Record all pre-set radio stations (if applicable).
3. Disconnect and isolate vehicle's negative battery terminal.

WARNING: Shock Hazard. Do not touch vehicle's negative battery terminal to vehicle's positive battery terminal. Serious injury and damage to the vehicle may occur.

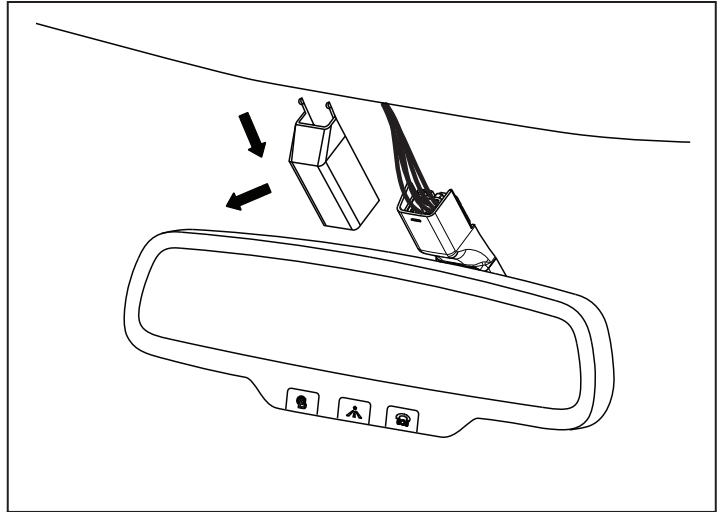

2

1. Slide upper portion of wire cover down from underneath headliner and pull out towards rear of vehicle to remove from mount.
2. Save upper portion of wire cover for reinstallation of new mirror.

Caution: Do not damage headliner or wire cover.

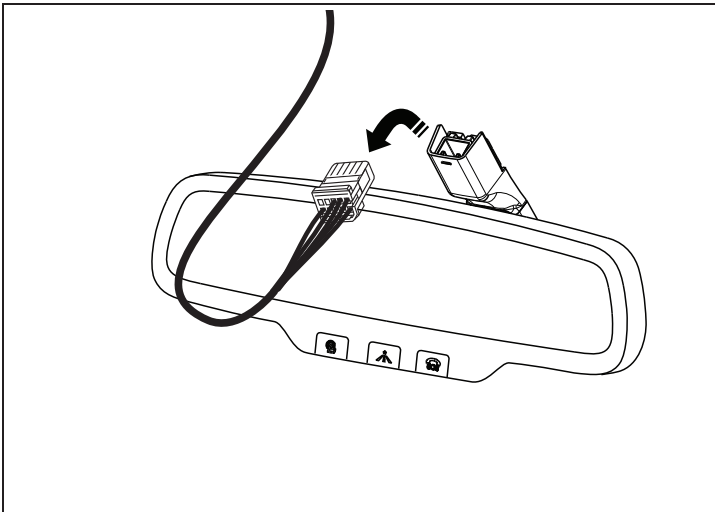

3

1. Unplug OEM wire harness from OEM mirror.

Caution: Do not damage headliner or connectors.

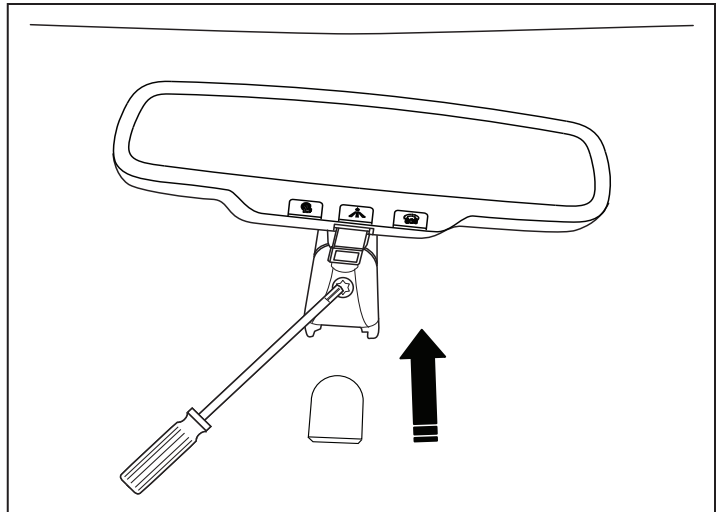

T20 Torx Driver 4

1. Loosen screw on mirror mount with a T20 Torx driver.
2. Gently slide mirror upwards in a parallel direction to the windshield. **DO NOT** pull away from windshield.

Caution: Ensure care is taken to prevent damage to mirror mount, windshield, and headliner.

HYUNDAI Genuine Accessories

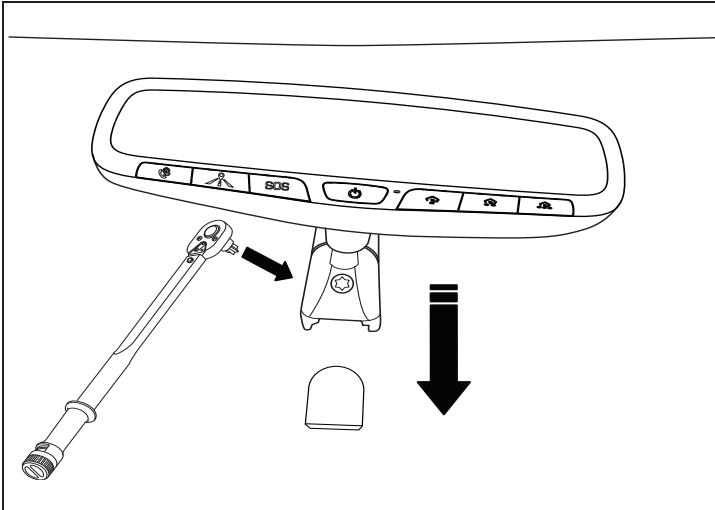

T20 Torx Socket & Torque Wrench 5

- NOTE
- Slide auto-dimming mirror onto windshield button
 - Tighten using T20 Torx Socket and Torque Wrench to 1.76 N-m (0.18 kgf-m, 15.6 lb-in)

WARNING: Do not over tighten screw. Tighten the mirror mounting bracket screw to 1.76 N-m (0.18 kgf-m, 15.6 lb-in). Over tightening the screw won't properly secure the mirror and could cause the mirror to break loose and injure the vehicle's occupants.

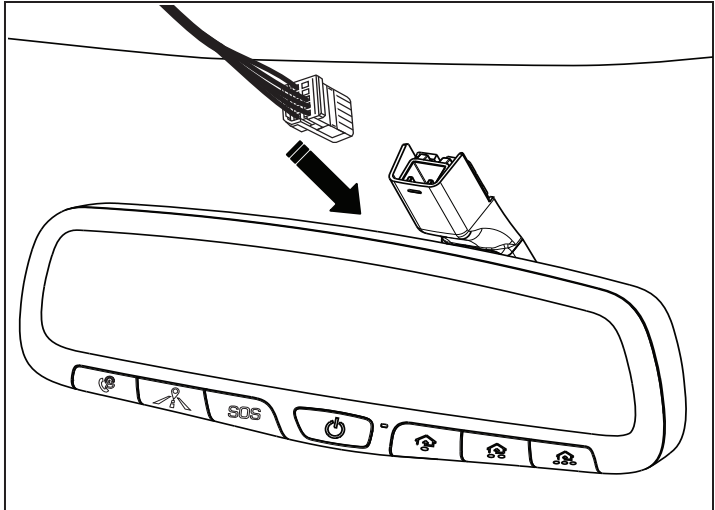

6

- NOTE
- Insert factory connector into mirror.

Caution: Ensure factory connector is fully seated into mirror.

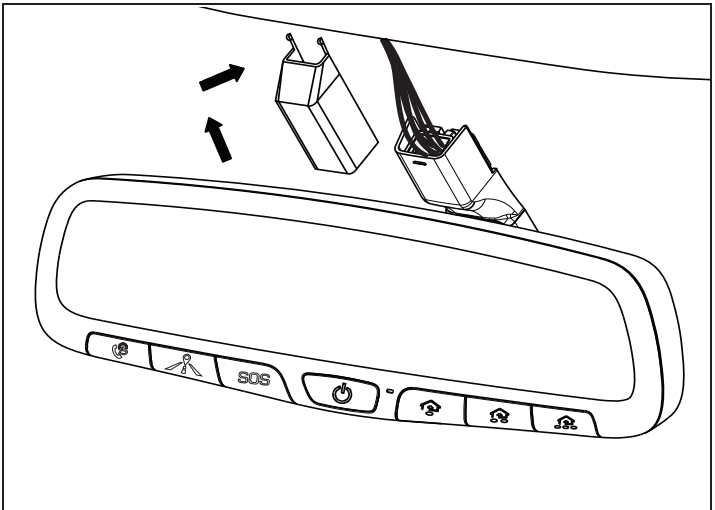

7

- NOTE
- Snap the upper portion of the wire cover onto lower wire cover of the mirror.
 - Slide the upper cover up until forks extend fully into headliner, while making sure cover is vertical.

Caution: Ensure upper portion of cover is properly seated onto lower cover on mirror and that the "forks" are properly seated under headliner. Ensure the cover is vertical without interference from harness.

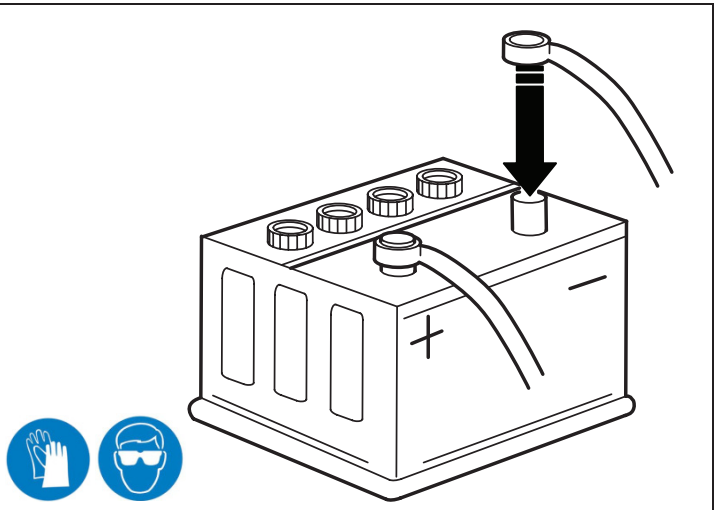

Ratchet and 10mm Socket 8

- NOTE
- Reconnect vehicle's negative battery terminal using a ratchet and 10mm socket.
 - Program radio pre-sets recorded in step 1 (if applicable).

WARNING: Shock Hazard. Do not touch vehicle's negative battery terminal to vehicle's positive battery terminal. Serious injury and damage to the vehicle may occur.

HYUNDAI Genuine Accessories Function Check

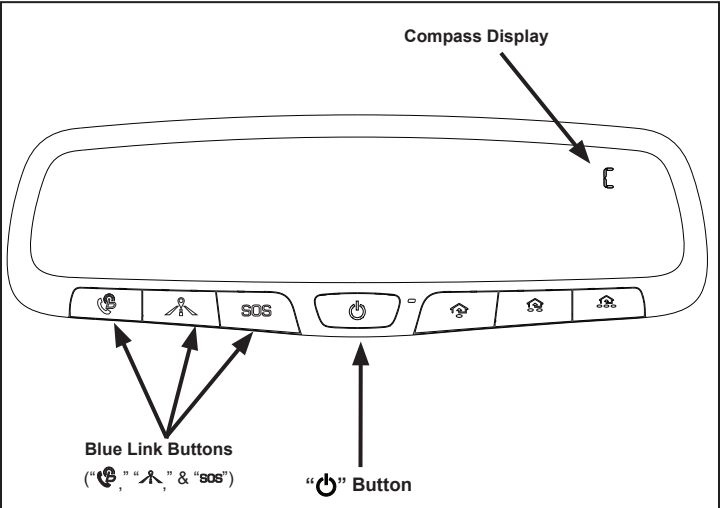
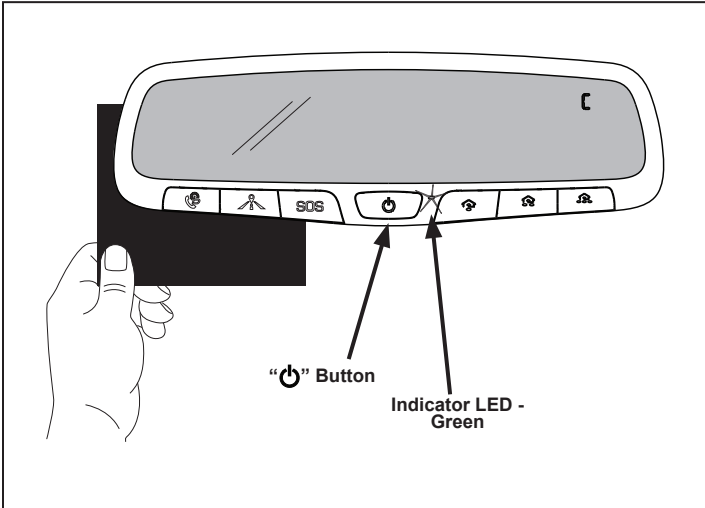

	1
M-H-O-Z	<ol style="list-style-type: none"> 1. Cover the forward looking photocell on the back of the mirror with a dark cloth or towel. 2. Turn the ignition to the "ON" position, making sure NOT to start the engine. 3. To make sure the auto-dimming feature is on, verify that the GREEN LED to the right of the center button is on. If it is not on, push and hold the "ON" button for 3 seconds to turn the GREEN LED on. 4. At this time, the mirror will begin to darken. 5. With the mirror covered, press the brake pedal and place the shift lever into the reverse position. The mirror should begin to clear. 6. Shift the vehicle into the park position and remove the cloth from the forward looking photo cell.
	WARNING: Do NOT accidentally start the vehicle when performing this function check.

	2
M-H-O-Z	<ol style="list-style-type: none"> 1. Verify that either a direction, such as NE, or "C" is displayed in the display window. If not, ensure the compass feature is turned on by pressing the "ON" button. 2. Ensure that the radio is ON. 3. Press each Blue Link button ("phone", "person", & "SOS"), one at a time. The appropriate Blue Link message will play once a button is pressed. Cancel the call and continue for each button.

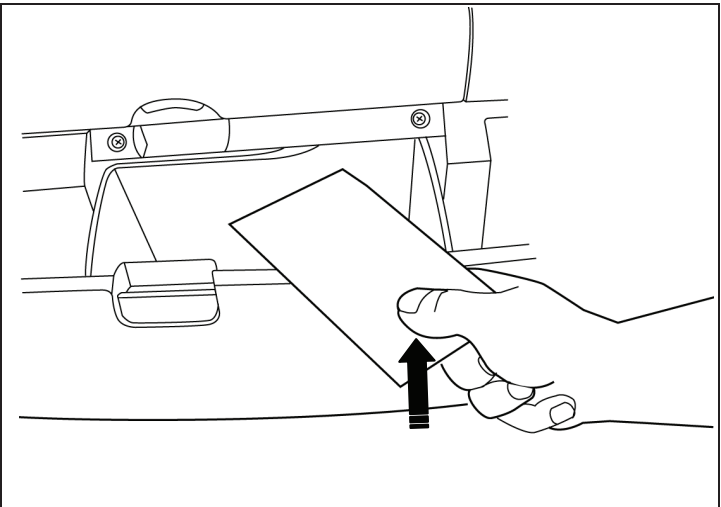
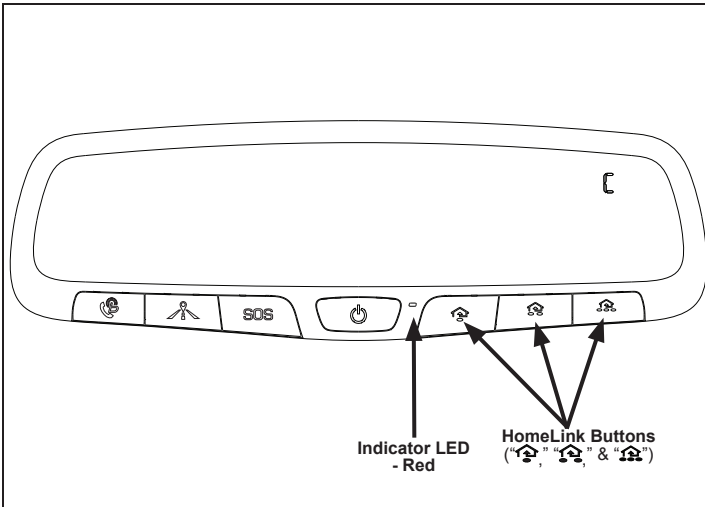

	3
M-H-O-Z	<ol style="list-style-type: none"> 1. Turn the ignition to the "OFF" position. 2. Ensure that the Compass display is no longer visible and the Green LED is no longer on. 3. Push each HomeLink button ("house", "car", & "truck"), one at a time, and verify that the LED indicator to the right of the center button illuminates with a RED LED when buttons are pressed. 4. Testing is now complete.

	4
M-H-O-Z	<ol style="list-style-type: none"> 1. Place Quick Reference Guide in vehicle glove box. 2. Remove fingerprints, smudges, etc. from mirror and windshield.
	DO NOT spray glass cleaner or other cleaning liquid directly onto the mirror as it may damage the electronics.



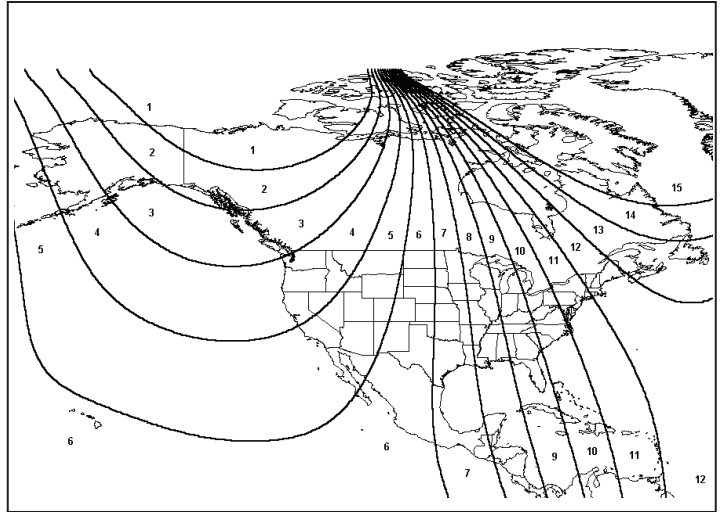
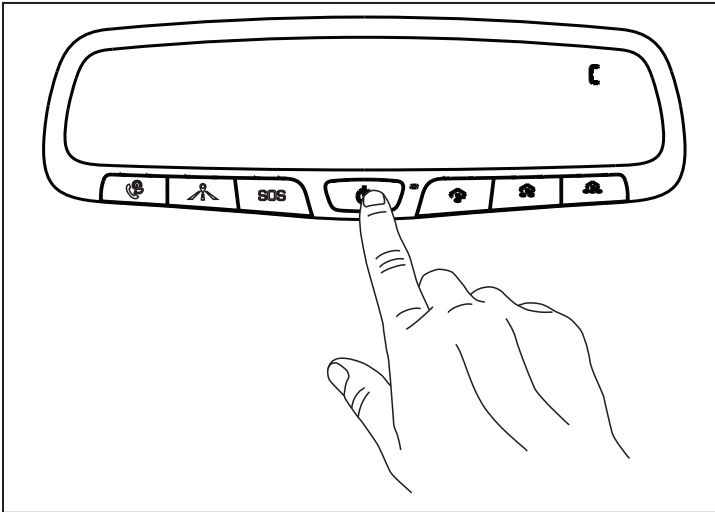





HYUNDAI Genuine Accessories Calibration (DEALER INSTALL ONLY)



1	
NOTE	<ol style="list-style-type: none"> 1. If the display reads "C," the compass feature must be calibrated. To calibrate the compass, drive the vehicle in up to 3 complete circles at less than 5 mph. 2. To adjust for compass variance: Press the "⏻" button for more than 9 seconds, or until the current Zone Number appears in the display.

2	
NOTE	<ol style="list-style-type: none"> 1. Find your current location and variance Zone Number on the zone map, shown above. 2. Press the "⏻" button until the new desired Zone Number appears in the display. Within a few seconds a compass direction will be displayed and the new zone is set. 3. Confirm compass direction.

Hyundai Genuine Accessories Visual Check

	Items to Be Checked	Results Of The Check
	Negative Battery Terminal Tightened 	Battery cable is correctly fastened to the negative terminal. WARNING: Shock Hazard. Do not touch vehicle's negative battery terminal to vehicle's positive battery terminal. Serious injury and damage to the vehicle may occur.
	Torx Screw	Torx screw is tightened to 1.76 N-m (0.18 Kgf-m, 15.6 lb-in).
	Harness	Factory mirror harness connector is securely fastened.
	Wire Cover	Ensure upper portion of cover is properly seated onto lower cover on mirror and that the "forks" are properly seated under headliner. Ensure cover is vertical without interference from harness.
	Blue Link	The appropriate Blue Link message will play once a button is pressed.
	Auto-Dimming	Mirror dims with ignition in the "ON" position when the forward looking photocell is covered. Mirror is clear and does <u>NOT</u> dim with ignition in the "OFF" position.
	Compass Display	Compass display reads either "C" or a directional heading with ignition in the "ON" position only and <u>NOT</u> in the "OFF" position.
	HomeLink	Red LED illuminates when each button is pushed with ignition in both the "OFF" and "ON" positions.

Hyundai Genuine Accessories Troubleshooting

Ensure Transport Fuse is ON/Installed

Blue Link	Press each button independently	No audio or visual message from audio/navigation unit	Reinstall original unit and check operation	If original unit does not operate, repair vehicle
			With Ignition <u>ON</u> , check for 12 Volts in pin #6 of factory harness.	If all checks are OK, replace unit
			Check vehicle grounds (refer to ETM)	
HomeLink	Press each button independently	Red LED does not illuminate after any button is pressed	Check for 12 Volts at T-tap in pin #10 of factory harness.	If all checks are OK, replace unit
		Red LED illuminates only for one or two buttons pressed	Check vehicle grounds (refer to ETM)	
			Replace unit	
Compass	Press Power Button	Compass display does not illuminate	With Ignition <u>ON</u> , check for 12 Volts in pin #6 of factory harness.	If all checks are OK, replace unit
			Check vehicle grounds (refer to ETM)	
Auto-Dimming	Press and Hold the Power Button for 3 seconds	Green LED does not illuminate	With Ignition <u>ON</u> , check for 12 Volts in pin #6 of factory harness.	If all checks are OK, replace unit
		Green LED illuminates, but mirror does not darken	Check vehicle grounds (refer to ETM)	
			Replace Unit	

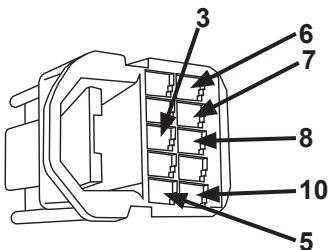

Factory Mirror Harness to Auto-dimming Mirror CONNECTOR PIN-OUT

NO.	GAGE	COLOR	FUNCTION	CIRCUIT	FUSE
1					
2					
3	22	LAV	Blue Link - Key Out (-)		
4					
5	22	PNK	Blue Link - Key In (+)		
6	22	ORG	IGNITION (Switched +12 Volts)		
7	22	LAV	Reverse Inhibit		
8	22	BLK	GROUND		
9					
10	22	GRN	BATTERY (Constant +12 Volts)		