

Genuine Accessories



Vehicle Model: Multiple

Model Year Multiple
 Part No. F2F05 AK102
 Language English
 Rev. Date 8/9/2019

Accessory: Sport Pedals (A/T)

Difficulty: (B)

Note: Difficulty stated above reflects the minimum level of expertise required to install the accessory:
 (A) Customer
 (B) Dealer Technician
 (C) Master Technician or Specialist

Instructional Symbols / Definitions

	Denotes warnings that may lead to serious physical injury or vehicle damage		Denotes quality processes to be checked prior to moving to the next step	Denotes personal protective equipment (PPEs) that may be required for a step. Examples of safety equipment icons noted below:	
	Denotes cautions to be taken to avoid physical injury or electronic component damage		Denotes specific tools that are necessary to complete a step		
	Denotes cautions to be taken to avoid vehicle and component damage	N O T E	Denotes important information to be reviewed during the step		
				Glasses	Gloves
				Mask	Hearing Protection

Basic Required Tools

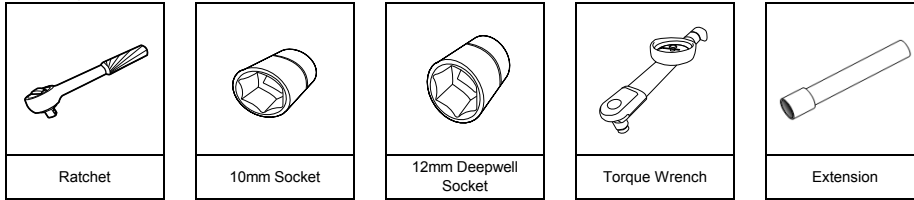

FMVSS 110 Compliance Information

All dealers must determine if the Net weight they have added in the form of all options or accessories, when added to the weight of all Port/Dealer Installed options or accessories, exceeds the lesser of 1.5% of GVWR or 100 lbs. If the additional weight does exceed the lesser of the indicated thresholds, a "Load Carrying Capacity Reduced" label must be installed. A black, fine-point, indelible marker must be used to write by hand onto the label, the reduced carrying capacity in kilograms or pounds, which is the total weight of all added options and accessories.
Load Label Part Number: NP070 - 09003

Notes to the installer:

- 1) Read the entire Installation Instructions prior to beginning the installation of the part.
- 2) Make sure the vehicle is completely clean and dry in the area(s) the part is to be installed.
- 3) Ensure the vehicle is properly protected in the area(s) that the accessory is to be installed.
- 4) NEVER place tools on painted surfaces, seating surfaces, dash pad, console or floor carpet/mats.
- 5) Always wear appropriate personal protective equipment, including gloves, safety glasses, etc., when required.



Part Weight (Gross)	1.01	lbs
	0.46	kg
Part Weight (Net)	0.18	lbs
	0.08	kg

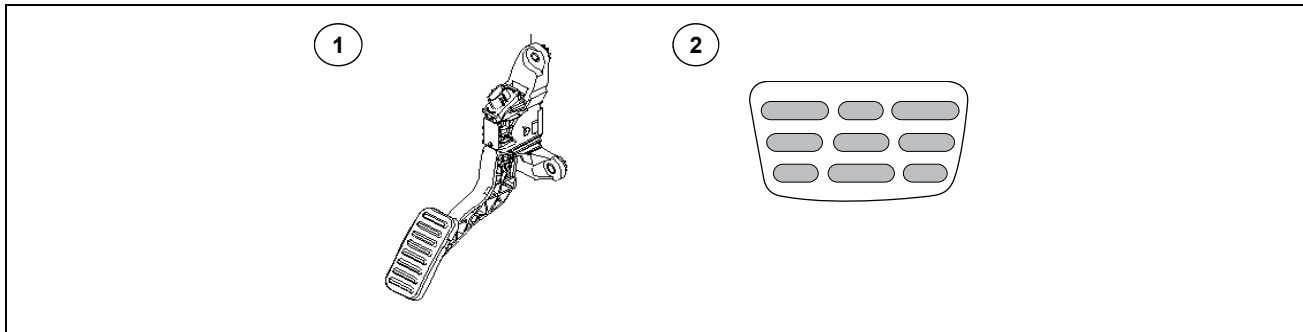

Kit Overview



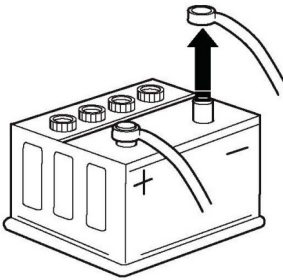

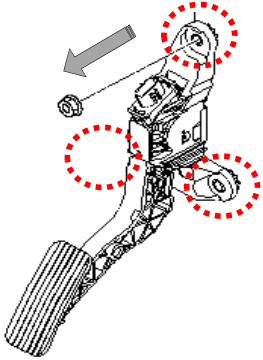

No.	Qty	Description
1	1	Accelerator Pedal Assembly
2	1	Brake Pedal Pad

Genuine Accessories

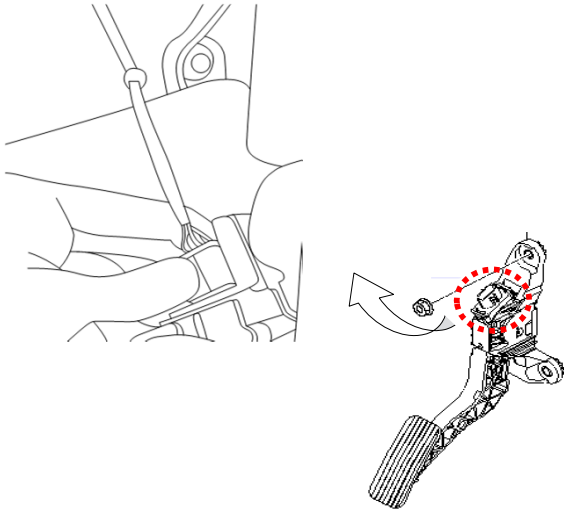

1		10mm Socket and Ratchet
		
N O T E	<p>A. Disconnect and isolate vehicle's negative battery cable.</p>	
	<p>WARNING! Shock Hazard. Do not touch vehicle's negative battery terminal to vehicle's positive battery terminal. Serious injury and damage to the vehicle may occur.</p>	

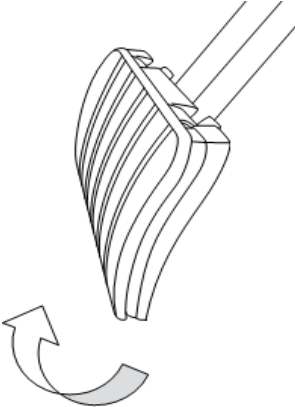
2		12mm Deepwell Socket, Extension, and Ratchet
		
		
N O T E	<p>A. Remove the three (3) M8 nuts from the original accelerator pedal assembly using a 12mm deepwell socket. B. Save the nuts for re-installation.</p>	
	<p>Be careful not to drop the nuts under the factory carpet.</p>	

3		
		
N O T E	<p>A. Disconnect the connector from the original accelerator pedal by pressing the side release tab, and pulling up and away from accelerator pedal as indicated by the arrow. B. Carefully remove the original accelerator pedal assembly from the vehicle.</p>	
	<p>Be careful not to damage the wire harness or connector when removing.</p>	



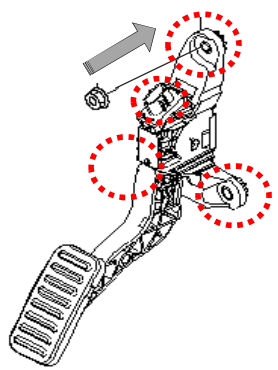

4		
		
		
N O T E	<p>A. Detach the original rubber brake pedal pad from the brake pedal and discard.</p>	

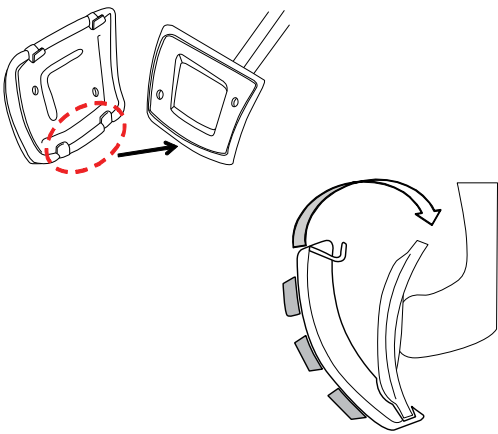
Genuine Accessories

5		12mm Deepwell Socket, Extension, Ratchet, and Torque Wrench
		
Torque: 12.8 ~ 15.7 N.m (1.3 ~ 1.6 kgf.m, 9.4 ~ 11.6 lb-ft)		
NOTE	A. Install the accessory accelerator pedal onto the three (3) M8 studs on the bulkhead. B. Install the three (3) M8 nuts removed in step 2. C. Torque the nuts to: 12.8 ~ 15.7 N.m (1.3 ~ 1.6 kgf.m, 9.4 ~ 11.6 lb-ft) . D. Reinstall the connector into the accessory accelerator pedal making sure it locks into place.	
	Make sure the connector is fully locked into the accessory accelerator pedal socket.	

6		10mm Wrench
		
NOTE	A. Engage lower hooks of accessory brake pad onto the lower part of the brake pedal. B. Rotate pad upwards and apply pressure to the upper part of the accessory brake pad until an audible 'click' is heard. C. Remove the protective film. D. Reinstall the negative battery cable and torque to: 5 Nm (0.5 kgf-m, 44.16 lb-in) .	

Visual Check

	Item to be Checked
	Do not leave the 10mm socket or ratchet in the engine compartment or on the battery after removing the negative battery cable.
	Check that the accelerator pedal functions as intended. Start vehicle, keep gear selector in park, and apply gentle pressure to the accelerator pedal. Do NOT test drive vehicle.
	Make sure all three (3) M8 nuts are torqued.
	Make sure the connector is fully locked into the accessory accelerator pedal socket.
	Brake pedal pad is fully engaged and not loose.

	Result
	10mm socket or ratchet is not in engine compartment or on battery.
	Accessory accelerator pedal does not bind and operates as intended.
	Three (3) M8 nuts are torqued properly.
	Electrical connector locked into accessory accelerator pedal socket.
	Brake pedal pad is properly installed.