

Genuine Accessories



Vehicle Model: **Elantra**

Accessory: **Mirror, Auto-dimming w/ HL5 and Compass**

Model Year 2019-
 Part No. F3F62 AU000 (DIO)
F3F62 AU600 (PIO)
 Language English
 Rev. Date 8/13/2018

Difficulty: **(B)**

Note: Difficulty stated above reflects the minimum level of expertise required to install the accessory:
 (A) Customer
 (B) Dealer Technician
 (C) Master Technician or Specialist

Instructional Symbols / Definitions

	Denotes warnings that may lead to serious physical injury or vehicle damage		Denotes quality processes to be checked prior to moving to the next step	Denotes personal protective equipment (PPEs) that may be required for a step. Examples of safety equipment icons noted below:	
	Denotes cautions to be taken to avoid physical injury or electronic component damage		Denotes specific tools that are necessary to complete a step		
	Denotes cautions to be taken to avoid vehicle and component damage	N O T E	Denotes important information to be reviewed during the step		
				Glasses	Gloves
				Mask	Hearing Protection

Basic Required Hand Tools

Ratchet	M10 10mm Deep Well Socket	Nylon Panel Removal Tool	#2 Phillips Screwdriver	T20 Torx Driver	T30 Torx Driver
Side Cutters	Pliers	T20 Torx Socket	Tape Measure	M12 12mm Socket	Torque Wrench

Part Weight (Gross)

1.30	lbs
0.59	kg

Part Weight (Net)

0.55	lbs
0.25	kg

FMVSS 110 Compliance Information

All dealers must determine if the Net weight they have added in the form of all options or accessories, when added to the weight of all Port/Dealer Installed options or accessories, exceeds the lesser of 1.5% of GVWR or 100lbs. If the additional weight does exceed the lesser of 1.5% of the indicated thresholds, a "Load Carrying Capacity Reduced" label must be installed. A black, fine-point, indelible marker must be used to write by hand onto the label, the reduced carrying capacity in kilograms or pounds, which is the total weight of all added options and accessories.
Load Label Part Number: NP070 - 09003

Notes to the installer:

- 1) Read the entire Installation Instructions prior to beginning the installation of the part.
- 2) Make sure the vehicle is completely clean and dry in the area(s) the part is to be installed.
- 3) Ensure the vehicle is properly protected in the area(s) that the accessory is to be installed.
- 4) NEVER place tools on painted surfaces, seating surfaces, dash pad, console or floor carpet/mats.
- 5) Always wear appropriate personal protective equipment, including gloves, safety glasses, etc., when required.
- 6) Record radio presets prior to disconnecting battery power, if needed.
- 7) Ensure the transportation fuse is set to "ON" before starting the install.
- 8) Roll down the driver's window and adjust the power seats (if applicable) prior to disconnecting battery power, if needed.
- 9) Factory wire harness colors are subject to change. Please use the specified pin number in the harness connector to identify the correct wire for T-Tap installation. If two wires are present in the pin, it does not matter which wire the T-Tap is installed on.



Genuine Accessories

Kit Overview

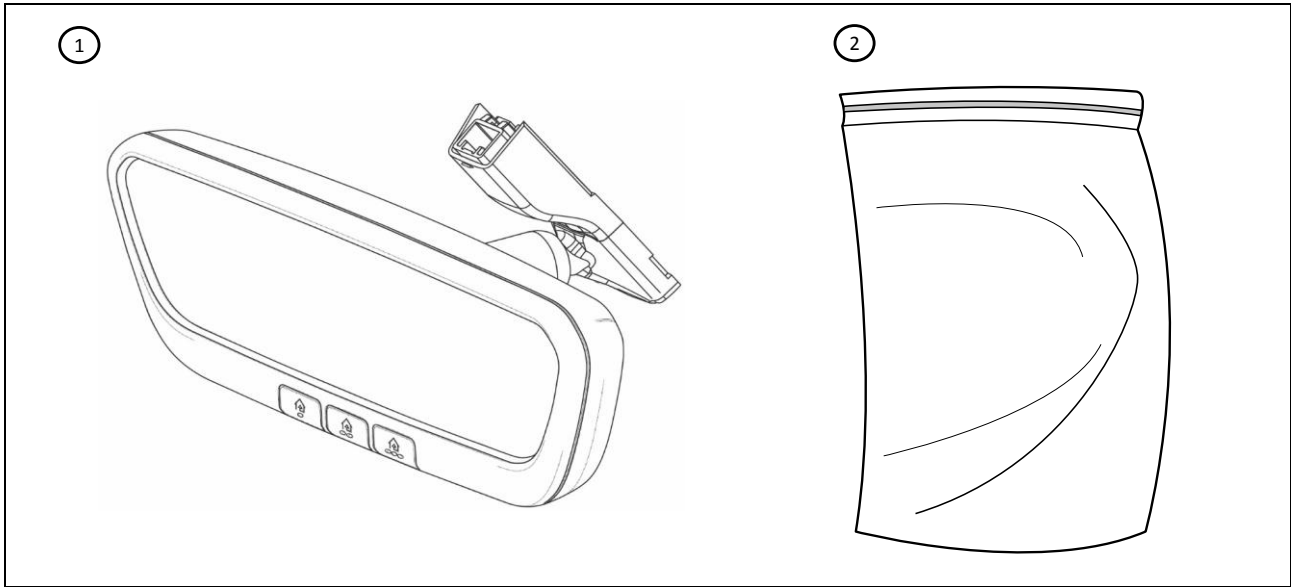

No.	Qty	Description
1	1	Mirror, Auto-dimming
2	1	Hardware Kit

Hardware Kit Contents

A		B		C		D		E	
1	Harness	1	Wire Cover	5	Foam Tape*	1	A-Pillar Tether Clip 85815 C1100	10	Wire Tie*
F		G							
1	Quick Reference Guide	2	T-Taps*						

* Indicates extra components intentionally included in kit as spares.
Follow instructions for proper placement of each component.

Hardware Total
21

Radio Presets - record customer preset frequencies if disconnecting battery power

FM1 _____ FM2 _____ FM3 _____ FM4 _____ FM5 _____
 FM6 _____ FM7 _____ FM8 _____ FM9 _____ FM10 _____
 AM1 _____ AM2 _____ AM3 _____ AM4 _____ AM5 _____
 SAT1 _____ SAT2 _____ SAT3 _____ SAT4 _____ SAT5 _____





Electrical Connection Procedure

WIRE CODES

Wires are either solid color or striped wires. The first color in the description indicates the base color of the wire, the second indicates the color of the stripe (or tracer).

Example:

<p>Solid Color Wire</p>  <p>Black</p> <p>Black wire</p>	<p>Striped Wire</p>  <p>White (Base Color)</p> <p>Red (Stripe Color)</p> <p>White w/ Red Tracer wire</p>
--	---

CONNECTOR DIAGRAMS

Connector diagrams show the harness side view. **The pin numbers are from the harness side view.**

Example:

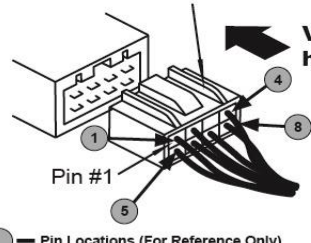

DISCONNECTING CONNECTORS

When disconnecting the wires, grasp the connectors, not the wires.

Example:

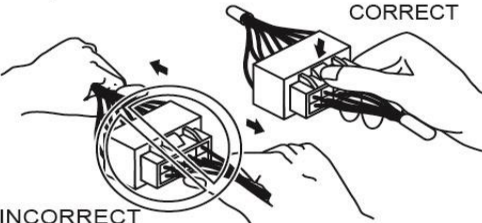

LOCKING CONNECTORS

When locking connectors, listen for a click, indicating they are securely locked.

Example:

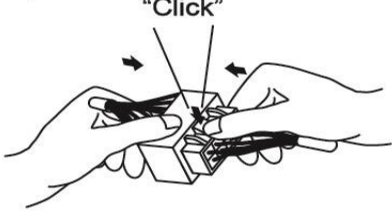

T-TAP INSTALLATION PROCEDURE

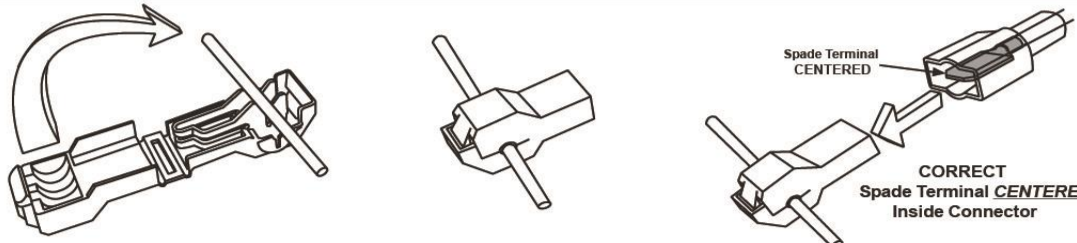

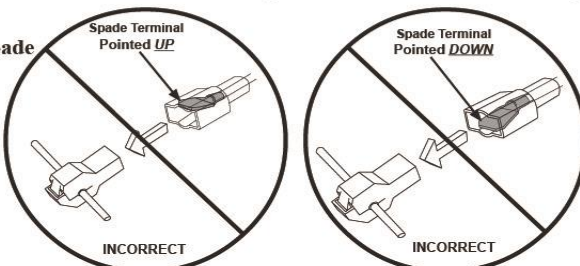

- Place the T-Tap on vehicle wire.
- Using pliers, close, and crimp T-Tap around vehicle wire.
- Insert EC Mirror Harness wire with male spade terminal end into the T-Tap.

****Extreme care must be taken to ensure that the male spade terminal is inserted into the T-Tap properly.**





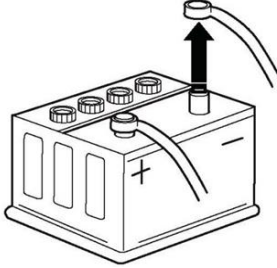

CORRECT
Spade Terminal *CENTERED*
Inside Connector

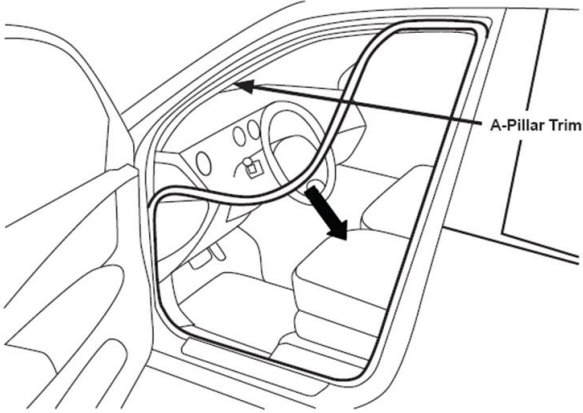
Genuine Accessories

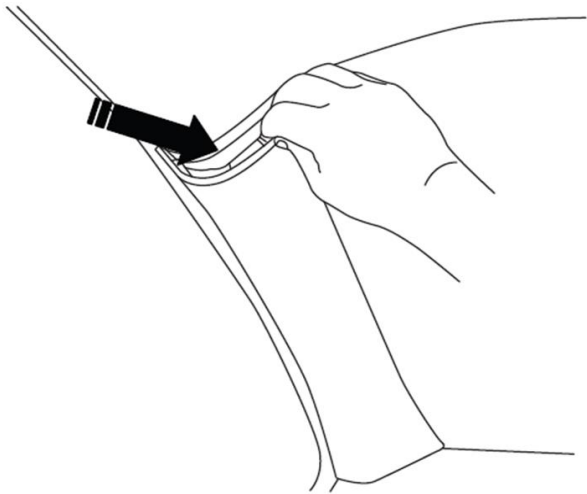
1		Ratchet and 10mm Deep Well Socket
		
		
N O T E	<p>A. Ensure the correct part is being installed. Verify the part number on the installation order with the part number on the kit box label.</p> <p>B. Write down all pre-set radio stations (if applicable).</p> <p>C. Open hood.</p> <p>D. Remove the negative (-) battery terminal cover, if applicable.</p> <p>E. Disconnect and isolate vehicle's negative (-) battery cable.</p>	
 <p>WARNING: Shock Hazard! Do not touch vehicle's negative battery terminal to vehicle's positive battery terminal. Serious injury and damage to the vehicle may occur.</p>		

2		
 <p style="text-align: right;">A-Pillar Trim</p>		
N O T E	<p>A. Carefully dislodge the front of the driver's side door weatherstrip back to allow removal of the A-pillar trim panel</p>	

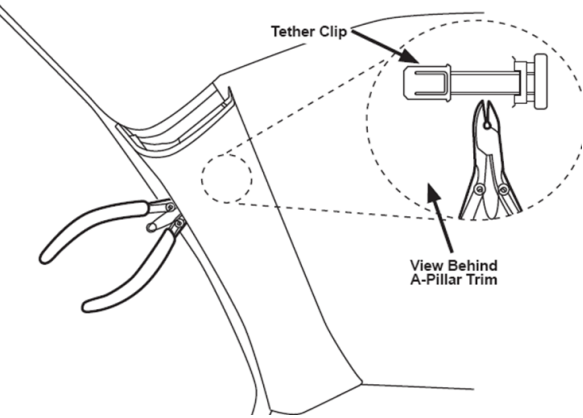
3		Nylon Panel Removal Tool
		
N O T E	<p>A. Partially remove the driver's side A-pillar trim panel by pulling the top out towards the passenger's side, until the A-pillar tether clip catches.</p>	
 <p>CAUTION: Ensure care is taken to prevent damage to the A-pillar trim panel, wire harness, sunroof drain tube (if applicable), and curtain airbag components.</p>		

4		Side Cutters
 <p style="text-align: right;">Tether Clip</p> <p style="text-align: right;">View Behind A-Pillar Trim</p>		
N O T E	<p>A. With A-pillar trim partially pulled away, reach behind trim panel and cut tether clip, as shown above.</p>	
 <p>CAUTION: If needed, use a flashlight to view behind the A-pillar trim, when using the side cutters, to avoid damaging any vehicle components. DO NOT cut anything other than the A-pillar tether clip.</p>		



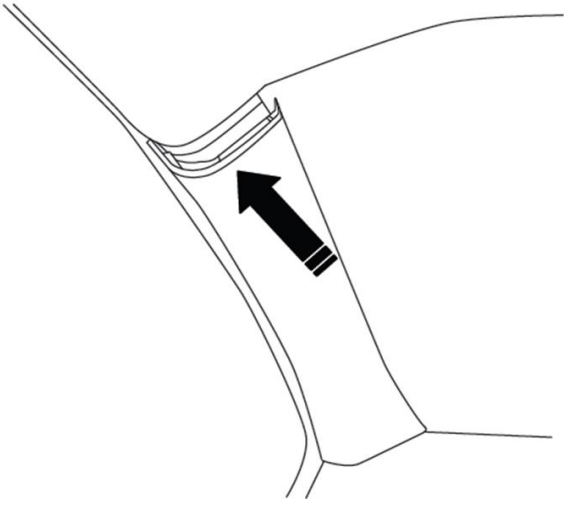

Genuine Accessories

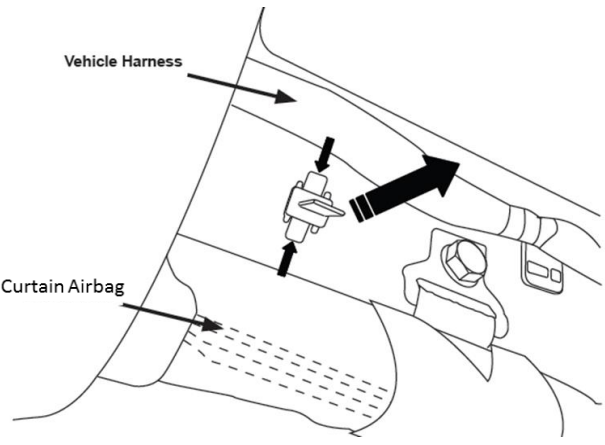

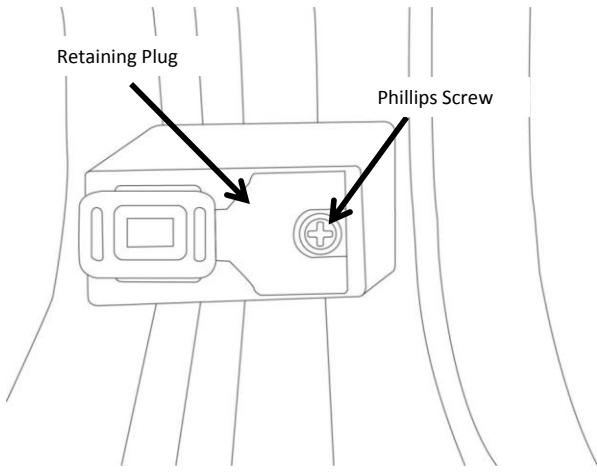
5		Nylon Panel Removal Tool
		
N O T E	<p>A. Continue removing the A-pillar trim panel by pulling the top out toward the passenger side of the vehicle, until one (1) remaining clip is released.</p> <p>- Use the Nylon Panel Removal Tool to dislodge the clip, if necessary.</p> <p>B. Remove A-pillar trim panel from vehicle.</p>	

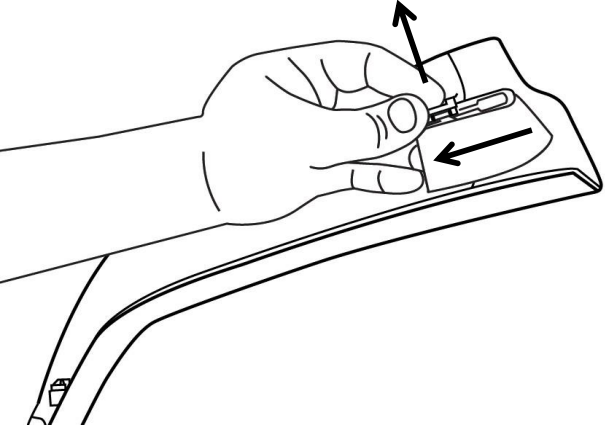

6		Pliers
		
N O T E	<p>A. Using pliers, pull the remaining portion of the A-pillar tether clip out of the A-pillar, and discard.</p> <p>- It may be helpful to push in the side tabs on the clip (indicated with the small arrows above), while pulling the clip out of the A-pillar.</p>	

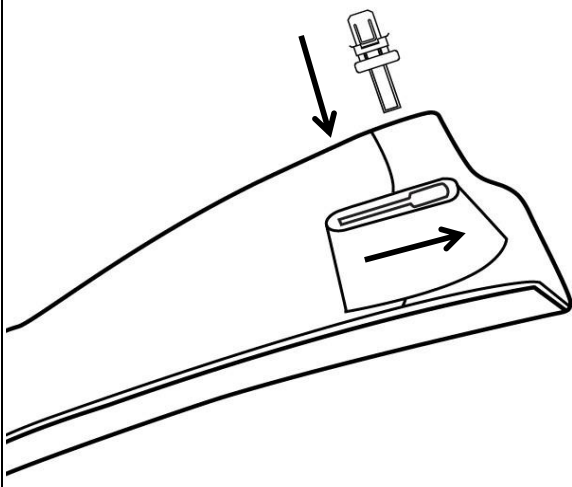

7		#2 Phillips Screwdriver
		
N O T E	<p>A. Remove one (1) Phillips screw, shown above, from inside of A-pillar trim.</p> <p>B. Remove retaining plug.</p>	

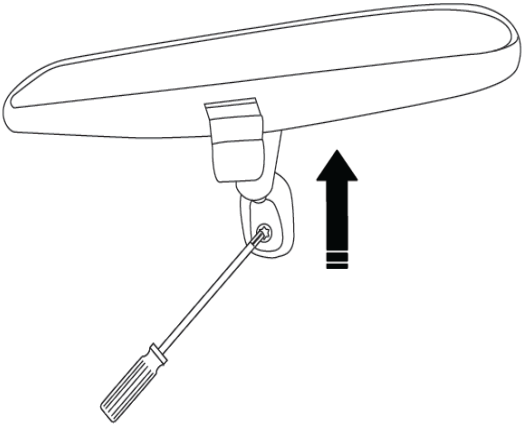

8		
		
N O T E	<p>A. Grasp the clip, and slide toward the bottom of the A-pillar trim, then pull the remaining clip piece out of the trim panel.</p> <p>B. Discard the clip.</p>	
		<p>CAUTION: Do NOT scratch or damage the A-pillar trim panel.</p>

Genuine Accessories

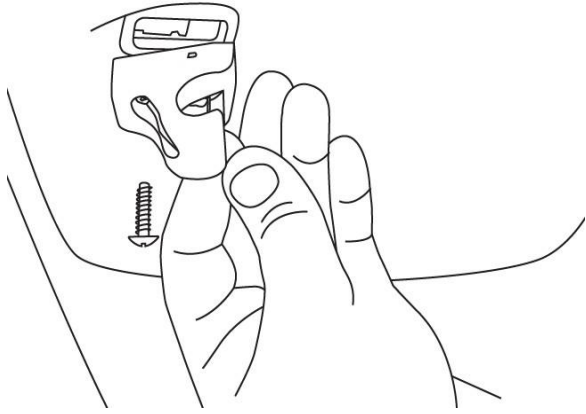

9		#2 Phillips Screwdriver
		
N O T E	<p>A. Place a new tether clip in the A-pillar trim panel by aligning the slot on the trim panel with the tether clip.</p> <p>B. Slide the clip upward until it locks in place.</p> <p>C. Re-install the retaining plug and screw, removed in the previous steps.</p> <p>D. Store the A-pillar trim panel in a safe location for reinstallation.</p>	
 <p>WARNING: ALWAYS use a new tether clip when reinstalling the A-pillar trim panel. Failure to use a new clip may result in serious injury or death in the event the airbag deploys. Do not damage the A-pillar trim panel or tether clip.</p>		

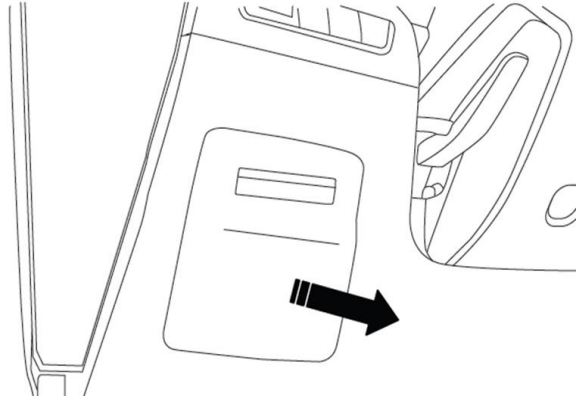

10		T20 Torx Screwdriver
		
N O T E	<p>A. Using a T20 Torx Driver, loosen the screw on the mirror mount.</p> <p>B. Gently pull the mirror upwards in a parallel direction to the windshield. DO NOT pull the mirror away from the windshield.</p>	
 <p>CAUTION: Take care to avoid damaging the mirror mount, windshield, and headliner.</p>		

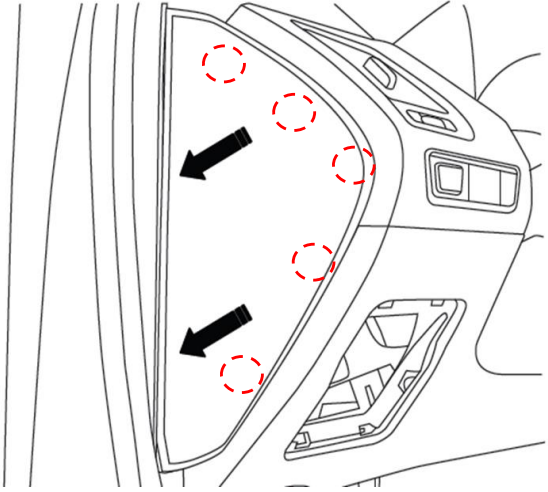

11		#2 Phillips Screwdriver and T30 Torx Driver
		
N O T E	<p>A. Remove Phillips or T30 Torx screw from driver side sun visor hook. Complete removal of sun visor hook is not necessary.</p> <p>B. Store the one (1) screw in a safe place for reinstallation.</p>	
 <p>CAUTION: Do NOT scratch the Fuse Panel Cover.</p>		

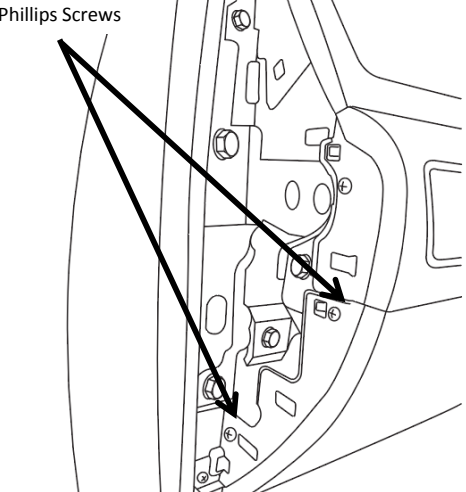

12		
		
N O T E	<p>A. Remove the fuse panel cover from the lower dash trim panel, and set aside in a safe location.</p>	
 <p>CAUTION: Do NOT scratch the Fuse Panel Cover.</p>		

Genuine Accessories

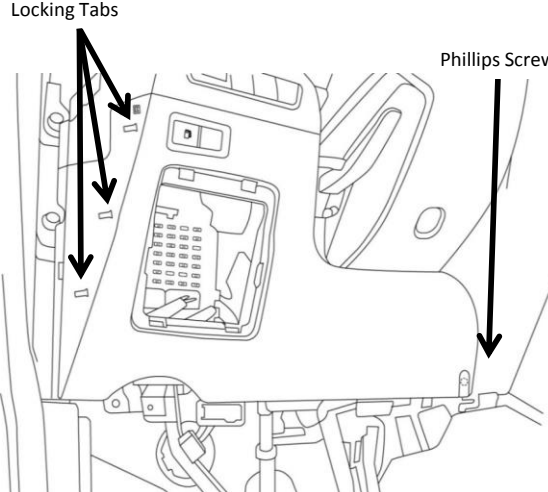
13		Nylon Panel Removal Tool
		
N O T E	<p>A. Reach through the fuse panel opening and push the dash side panel out, with a Nylon Panel Removal Tool, to dislodge the five (5) clips. B. Remove the Dash Side Panel and set aside in a safe place.</p>	
	<p>CAUTION: Do NOT scratch the Dash Side Panel.</p>	

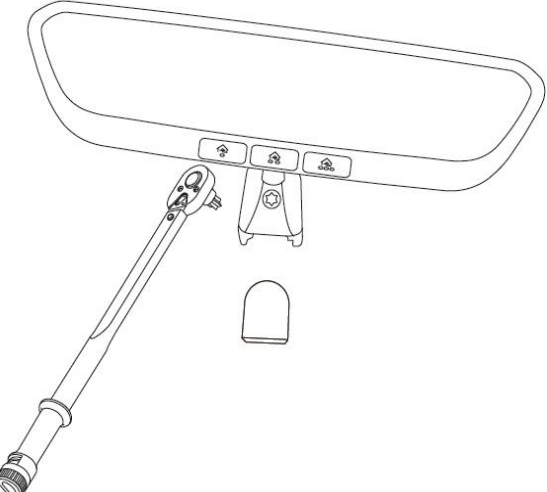

14		#2 Phillips Screwdriver
		
N O T E	<p>A. Using a screwdriver, remove the two (2) Phillips screws from the outside surface of the lower dash trim panel. B. Set the two (2) screws aside in a safe location for reinstallation.</p>	
	<p>CAUTION: Do not scratch lower dash trim panel.</p>	



15		#2 Phillips Screwdriver & Nylon Panel Removal Tool
		
N O T E	<p>A. Remove one (1) Phillips screw from lower right corner of lower dash trim panel. B. Using the Nylon Panel Removal Tool, release the three (3) locking tabs on the lower dash trim panel. C. Starting at the upper right side of the lower dash trim panel, pull the panel outward releasing the clips, moving right to left. D. Disconnect the OBDII connector and any electrical connectors, if applicable, from the lower dash trim panel. E. Store the one (1) screw and panel in a safe location for reinstallation.</p>	
	<p>CAUTION: Do not scratch the lower dash trim panel. Do not damage wires or connectors in the panel.</p>	

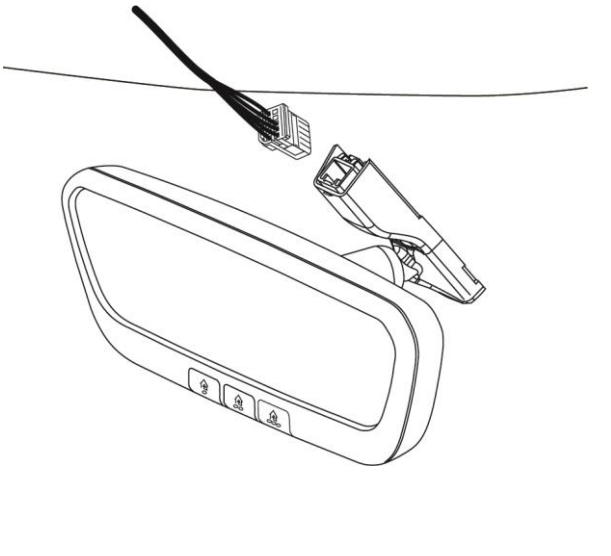

16		T20 Torx Bit and Torque Wrench
		
N O T E	<p>A. Slide the new mirror over the windshield button. B. Using a torque wrench and T20 Torx Bit, torque the T20 Torx screw to: 1.76 N-m (0.18 kgf-m, 15.6 lb-in).</p>	
	<p>WARNING: Do not over-tighten the screw. Over tightening the screw will not properly secure the mirror and could cause the mirror to break loose and injure the occupants in an accident.</p>	



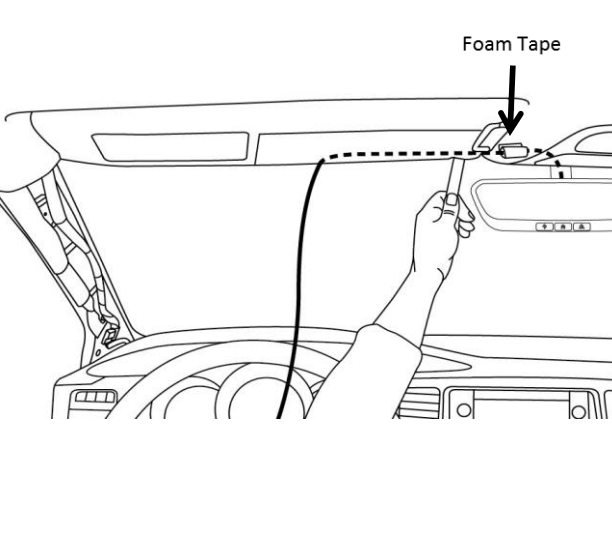

Genuine Accessories

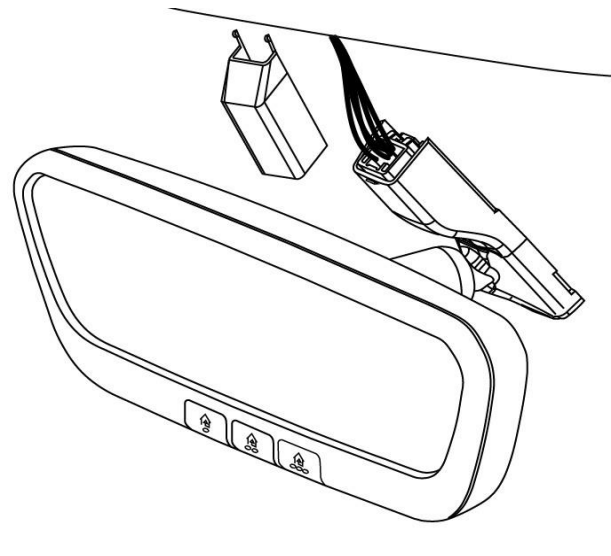
17		
		
N O T E	<p>A. Plug the 10-pin connector of the provided mirror harness into the mirror and ensure it is locked in place.</p>	
	<p>CAUTION: Ensure 10-pin connector is securely installed.</p>	

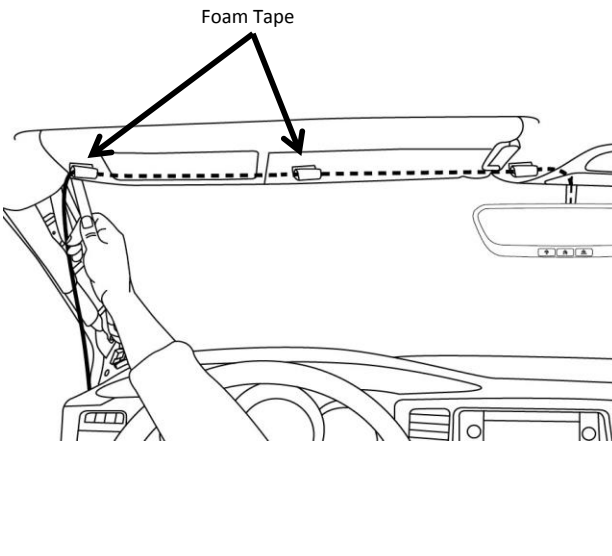

18		Tape Measure and Nylon Panel Removal Tool
		
N O T E	<p>A. Wrap one (1) piece of foam tape around the harness four (4) inches from the mirror connector. B. Using a Nylon Panel Removal Tool, begin tucking the mirror harness between the headliner and the roof. Stop after the foam-taped harness connector is hidden under the headliner.</p>	
	<p>CAUTION: Use caution when working with the headliner to prevent creases or damage. Make sure hands are clean.</p>	



19		
		
N O T E	<p>A. Slide the provided wire cover over the mirror harness lead, and click it into the top surface of the mirror base. B. Extend the upper wire cover until it hooks onto the headliner. Ensure the cover is vertical.</p>	
	<p>CAUTION: Ensure cover "forks" are properly seated into headliner.</p>	

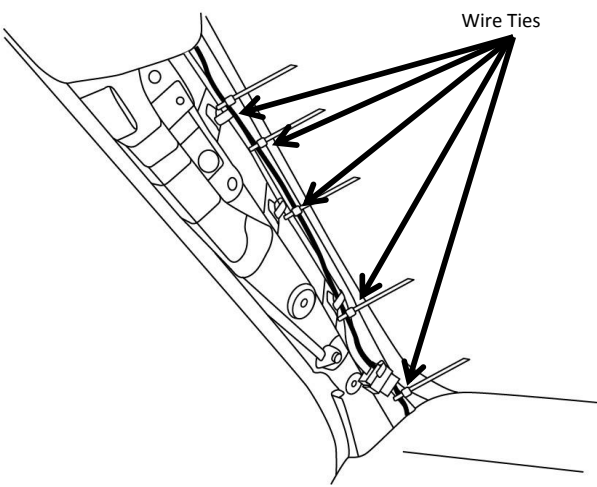

20		Nylon Panel Removal Tool
		
N O T E	<p>A. Hold the mirror harness against the headliner and wrap one (1) foam tape around the harness where it meets the corner of the A-pillar. B. Wrap one (1) foam tape on the harness between the two previously installed foam tapes. C. Tuck the harness with the wrapped foam tape into the headliner and the roof across from the mirror to the A-pillar.</p>	
	<p>CAUTION: Use caution when working with the headliner to prevent creases or damage. Make sure hands are clean.</p>	

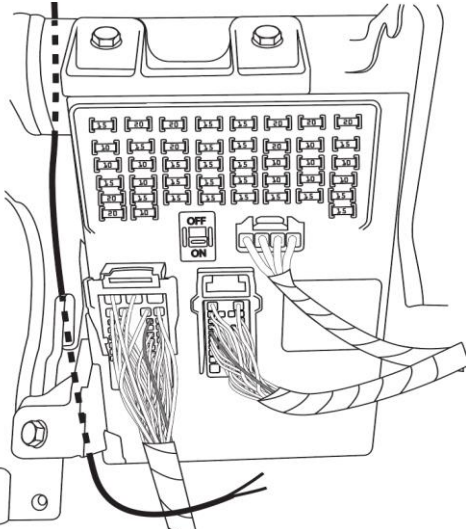

Genuine Accessories

21		Side Cutters
		
N O T E	<p>A. Route mirror harness down the A-pillar into the dash, toward engine side of fuse panel. NOTE: Ensure wire harness is routed away from the curtain airbag and sunroof drain tube, if applicable.</p> <p>B. Secure mirror harness near the vehicle harness clips, and above the electrical connector at the bottom of the A-pillar, with five (5) wire ties.</p> <p>C. Trim the excess wire tie length.</p>	
<p> CAUTION: DO NOT secure to airbag inflator. DO NOT secure to sunroof drain tube, if equipped.</p>		

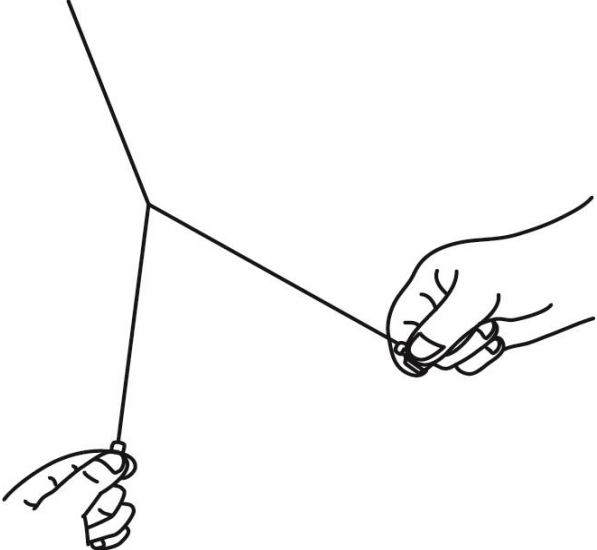
22		
		
N O T E	<p>A. Route mirror harness through dash, on the engine-side of the junction block.</p> <p>B. Route mirror harness behind the left side of the junction block, as shown above, pulling the two (2) terminals toward the driver's seat.</p>	
<p> CAUTION: Ensure harness does not catch on vehicle component, or is damaged during the routing.</p>		

23		Tape Measure
		
N O T E	<p>A. Pull mirror harness wires apart approximately 300mm (12in), as shown.</p>	
<p> CAUTION: DO NOT use a razor blade or any other sharp tool to separate the wires. Ensure wire is not damaged during separation.</p>		

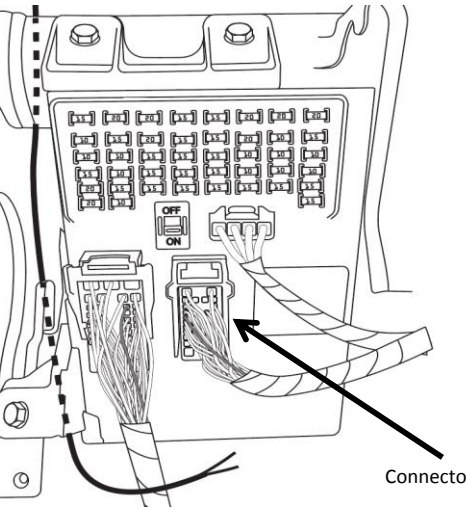
24		
		
N O T E	<p>A. Locate Connector D (38-Pin connector) on the front side of the junction block (furthest side from the engine).</p>	



Genuine Accessories

25 

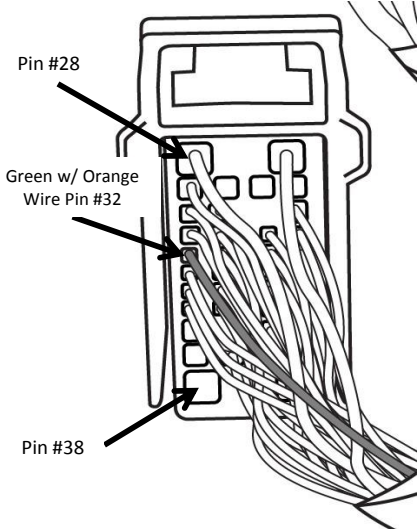

Pin #28

Green w/ Orange Wire Pin #32

Pin #38

A. Locate Pin #32 (GREEN w/ ORANGE wire) in Connector D.

N O T E

 **CAUTION:** Ensure the correct wire is identified.
NOTE: Factory wire colors are subject to change at any time. Refer to the pin number to correctly identify the circuit.

26  Pliers

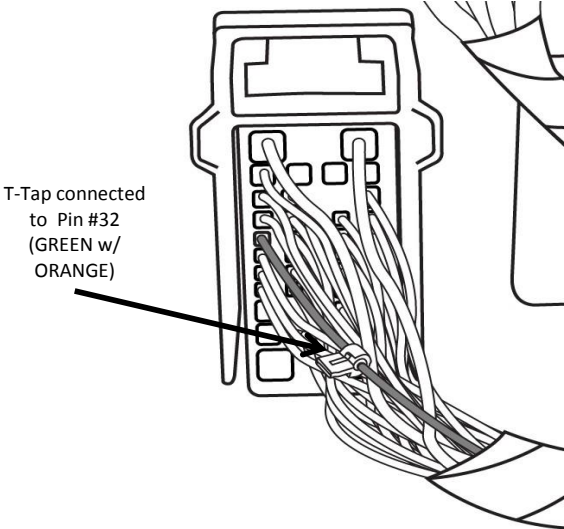

T-Tap connected to Pin #32 (GREEN w/ ORANGE)

A. Attach one (1) T-Tap to the wire at Pin #32 (GREEN w/ ORANGE wire). Use Pliers to snap the T-tap together.
- Refer to the Electrical Connection Procedure at the beginning of the instructions for more details.

N O T E

 **CAUTION:** Ensure that the wire is in the slot of the T-Tap, and that both halves of the T-Tap are snapped together properly.

27 

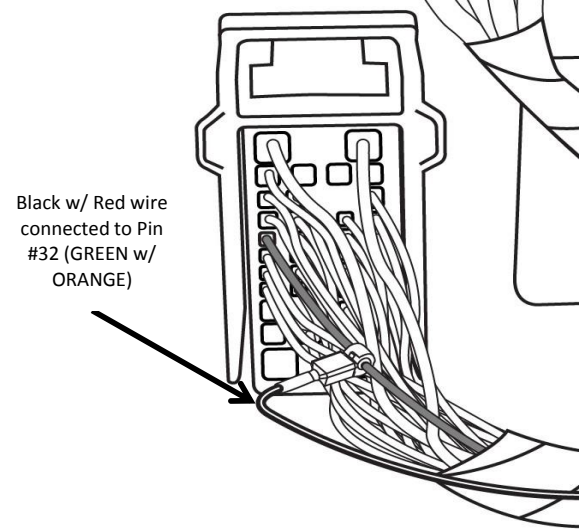

Black w/ Red wire connected to Pin #32 (GREEN w/ ORANGE)

A. Insert male spade terminal of the mirror harness (Black w/ Red wire) into the T-Tap connector (GREEN w/ ORANGE wire), for switched ignition power.
- Refer to the Electrical Connection Procedure at the beginning of the instructions for more details.

N O T E

 **CAUTION:** Ensure the male spade connector is fully inserted into the T-Tap. Check that the spade did not "miss" the female slot. Check that the male spade is not visible on either side of the female connector.

28  12mm Socket & Ratchet

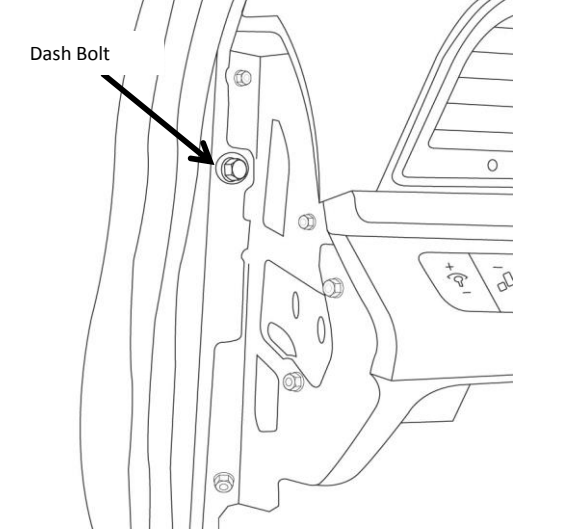



Dash Bolt

A. Locate the 12mm dash bolt, on the dash just above the drivers side door hinge.
B. Remove the 12mm dash bolt.



N O T E

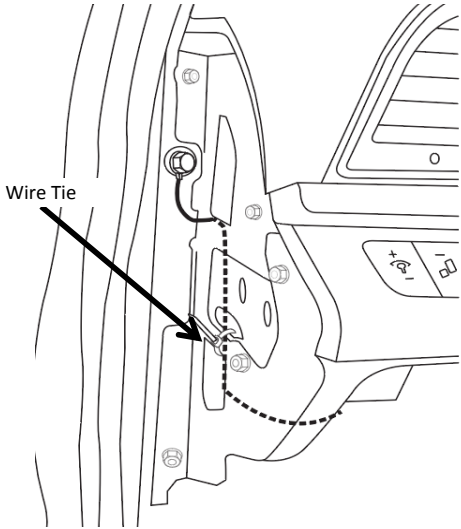

Genuine Accessories

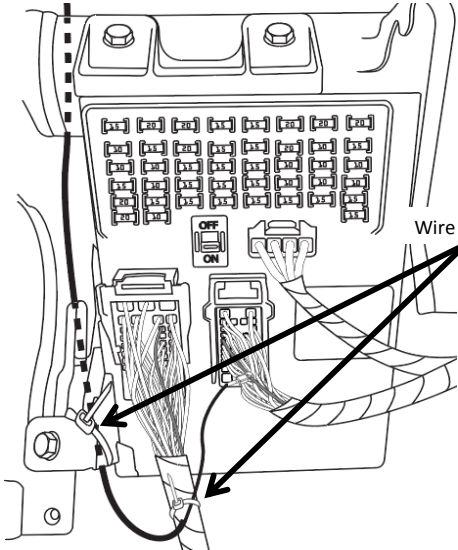
29		12mm Socket, Torque Wrench, & Side Cutters
		
N O T E	<p>A. Route ground wire with ring behind plastic dash pieces as shown above.</p> <p>B. Place the ground wire ring of the mirror harness onto the dash bolt as shown.</p> <p>C. Secure the dash bolt, and torque to: 16.7 ~ 21.6 N.m (1.7 ~ 2.2 kgf.m, 12.3 ~ 15.9 lb-ft).</p> <p>D. Secure ground wire to plastic dash support with one (1) wire tie as shown.</p> <p>E. Trim excess wire tie material.</p>	
	<p>CAUTION: Ensure the dash bolt is secure.</p>	

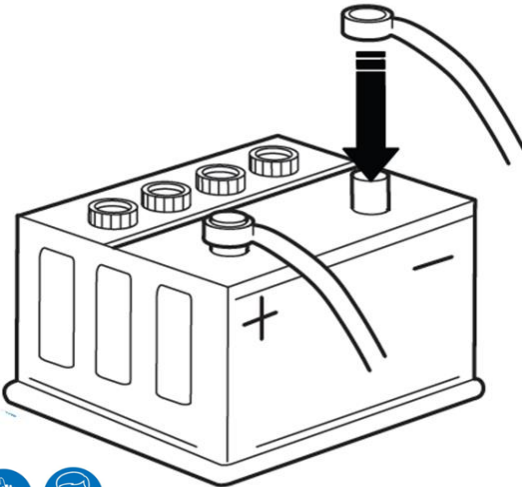
30		Side Cutters
		
N O T E	<p>A. Take up any excess harness slack and secure to vehicle harness with two (2) wire ties, as shown.</p> <p>B. Trim excess wire tie length.</p>	

31		Ratchet, 10mm Deep Well Socket and Torque Wrench
		
N O T E	<p>Function Check Preparation:</p> <p>A. Reconnect the negative battery cable, and torque to: 5.0 ~ 6.0 N.m (0.50 ~ 0.60 kgf.m, 45 ~ 52 lb-in).</p> <p>B. Reinstall the negative (-) battery terminal cover, if applicable.</p>	
	<p>WARNING: Shock Hazard! Do not touch vehicle's negative battery terminal to vehicle's positive battery terminal. Serious injury and damage to the vehicle may occur.</p>	

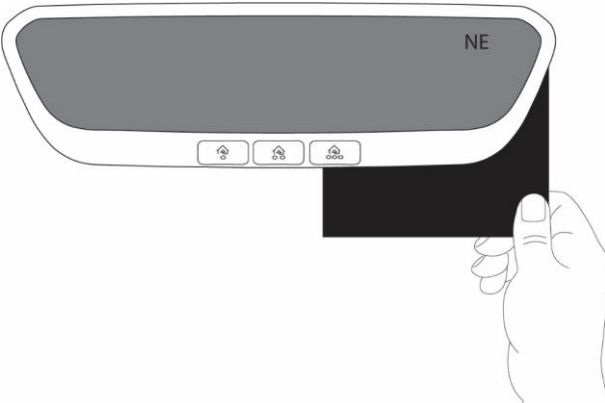
32		
		
N O T E	<p>A. Cover the forward-facing photocell with a dark cloth or towel.</p> <p>B. Turn the ignition to "ON".</p> <p>C. With the dark cloth in place and the power on, the mirror will darken.</p> <p>D. Remove the dark cloth and the mirror will return to normal.</p>	



Genuine Accessories

33 

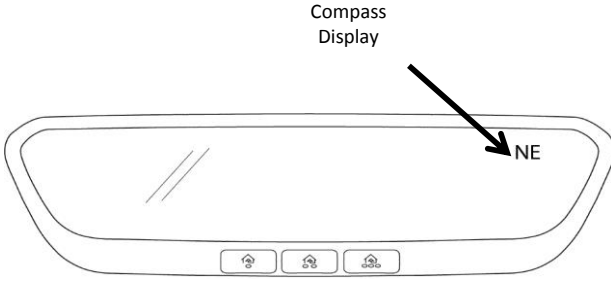

Compass Display

NE

NOTE

A. Verify that a direction (such as "NE" or "C") is displayed in the display window.

34 

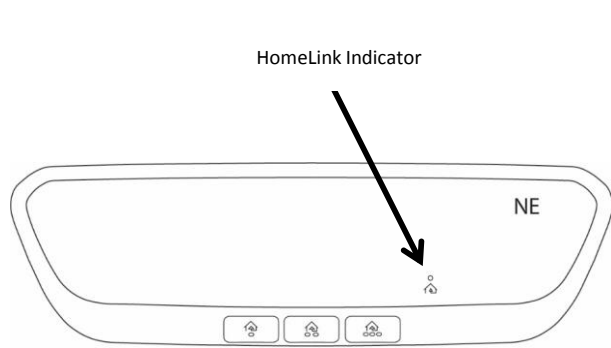

HomeLink Indicator

NE

NOTE

A. Ensure that the ignition is still "ON"
 B. Press each HomeLink button, one-at-a-time, and verify that the LED indicator illuminates from behind the glass. Press the HomeLink button a second time to turn off the feature.

35 

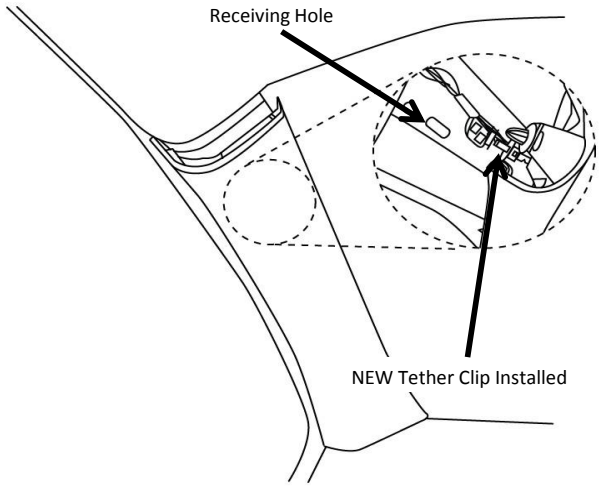



Receiving Hole

NEW Tether Clip Installed

NOTE

A. Ensure a new tether clip has been inserted into the A-pillar trim panel.
 B. Insert the A-pillar trim panel lower surface into the mating surface on the top of the dash panel.
 C. Move the panel closer to the A-pillar, aligning the clips with their corresponding holes. Carefully snap the panel into place.
 D. Reinstall the lower dash panel (ensuring the OBDII and any electrical connectors, if applicable, are reconnected), side dash panel, fuse panel cover, sun visor hook screw, overhead console screws and door weatherstrip.

 **WARNING:** Always use a new tether clip when re-installing the A-pillar trim panel. Failure to use a new clip may result in serious injury or death in the event the airbag deploys. Do not damage the A-pillar trim panel or tether clips.

36 

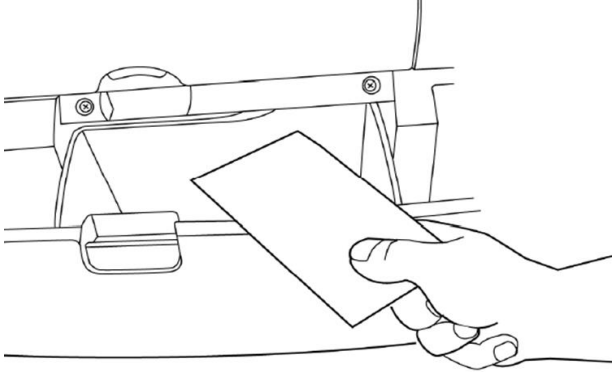

NOTE

A. Place the provided Quick Reference Guide in the glove box.
 B. Clean fingerprints, smudges, etc. from mirror and windshield.

 **CAUTION:** DO NOT spray glass cleaner or other cleaning liquid directly on the mirror as it may damage the electronics.

Genuine Accessories

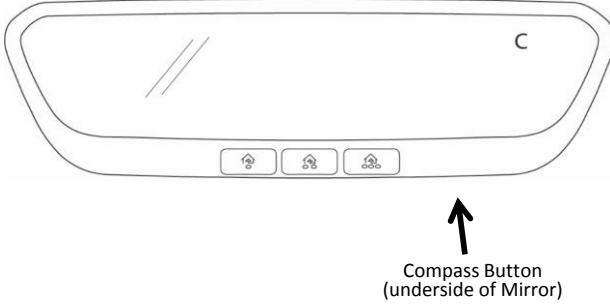

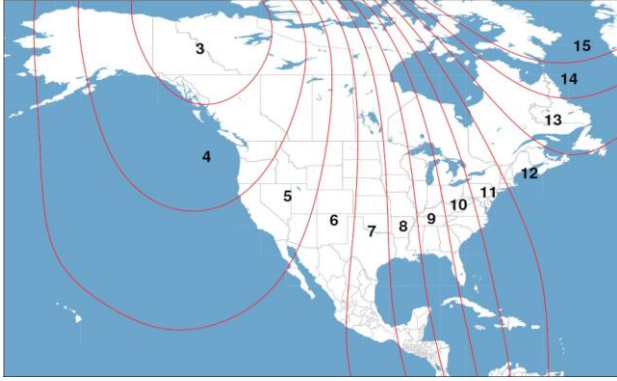







A	🔑	Dealer Only
COMPASS CALIBRATION		
		
N O T E	<p>A. If the compass displays "C", it will need to be calibrated.</p> <p>B. To calibrate, drive the vehicle in up to three (3) complete circles, at less than 5mph.</p>	

B	🔑	Dealer Only
COMPASS CALIBRATION		
		
N O T E	<p>A. Identify your approximate compass region on the above map.</p> <p>B. Using a paper clip, press and hold the compass button for more than 6 seconds and the current compass region code will display.</p> <p>C. Press the compass button until your desired compass region is displayed. Release the button and the correct compass direction will appear.</p>	



Genuine Accessories







Visual Check

Item to be Checked		Result	
	Negative battery terminal re-tightened and reinstalled terminal cover, if applicable	Battery cable is correctly fastened to the negative terminal. Nut is properly torqued. Battery terminal cover, if applicable, has been reinstalled.	
	Mirror Torx screw replaced and re-tightened	Screw is tightened and properly torqued.	
	Mirror Harness	Mirror harness connectors are properly connected. T-Tap spade connector is properly seated. Harness is tucked into the headliner without causing a bulge or interference.	
	Sun visor hook	Hook is properly secured in place, and screw is tightened.	
	A-pillar trim panel	Panel is securely in place. Ensure A-pillar tether clip is properly installed and seated in the A-pillar correctly.	
	Dash bolt	Dash bolt is tightened and properly torqued for harness ground.	
	Lower dash trim panel	Panel is securely in place. All connectors attached are properly re-connected.	
	Side dash trim panel	Panel is securely in place.	
	Fuse panel access cover	Panel is securely in place.	
	Door weatherstrip	Weatherstrip is properly reinstalled, and not wrinkled.	



Genuine Accessories

Troubleshooting

	Issue / Concern	Items to be Checked
	Mirror does not power up	<p>Confirm ground circuit connector is properly attached and locked in place.</p> <ul style="list-style-type: none"> -Check that mirror harness is properly connected at mirror. -Check that GND ring terminal is seated solidly against vehicle body at dash bolt. -Check that wire is not damaged.
	↑	<p>Confirm ignition-switched power circuit is properly connected. Circuit should NOT have power with ignition in "OFF", but should have 12V power when ignition is switched to "ON".</p> <ul style="list-style-type: none"> -Check that mirror harness is properly connected at mirror. -Check that T-Tap is connected to the proper wire. -Check that T-Tap is fully crimped. -Check that male spade is correctly inserted in T-Tap. -Check that wire is not damaged.
	Homelink does not work (House indicator does not illuminate)	<ul style="list-style-type: none"> -Check that the vehicle ignition is in the ON position. -Check that T-Tap is connected to the proper wire. -Check that T-Tap is fully crimped. -Check that male spade is correctly inserted in T-Tap. -Check that GND ring terminal is seated solidly against vehicle body at dash bolt. -Check vehicle Module 2, 10 amp fuse
	Homelink does not work (House indicator does not illuminate)	-Replace the mirror.
	Compass does not illuminate	<ul style="list-style-type: none"> -Check that the vehicle ignition is in the ON position. -Check that T-Tap is connected to the proper wire. -Check that T-Tap is fully crimped. -Check that male spade is correctly inserted in T-Tap. -Check that GND ring terminal is seated solidly against vehicle body at dash bolt. -Check vehicle Module 2, 10 amp fuse
	Auto-dimming function does not work properly	<ul style="list-style-type: none"> -Check that the vehicle ignition is in the ON position. -Check that T-Tap is connected to the proper wire. -Check that T-Tap is fully crimped. -Check that male spade is correctly inserted in T-Tap. -Check that GND ring terminal is seated solidly against vehicle body at dash bolt. -Check Module 2 fuse.
	Auto-dimming function does not work properly	-Replace the mirror.



Genuine Accessories

Wiring Diagram

Smart Junction Box

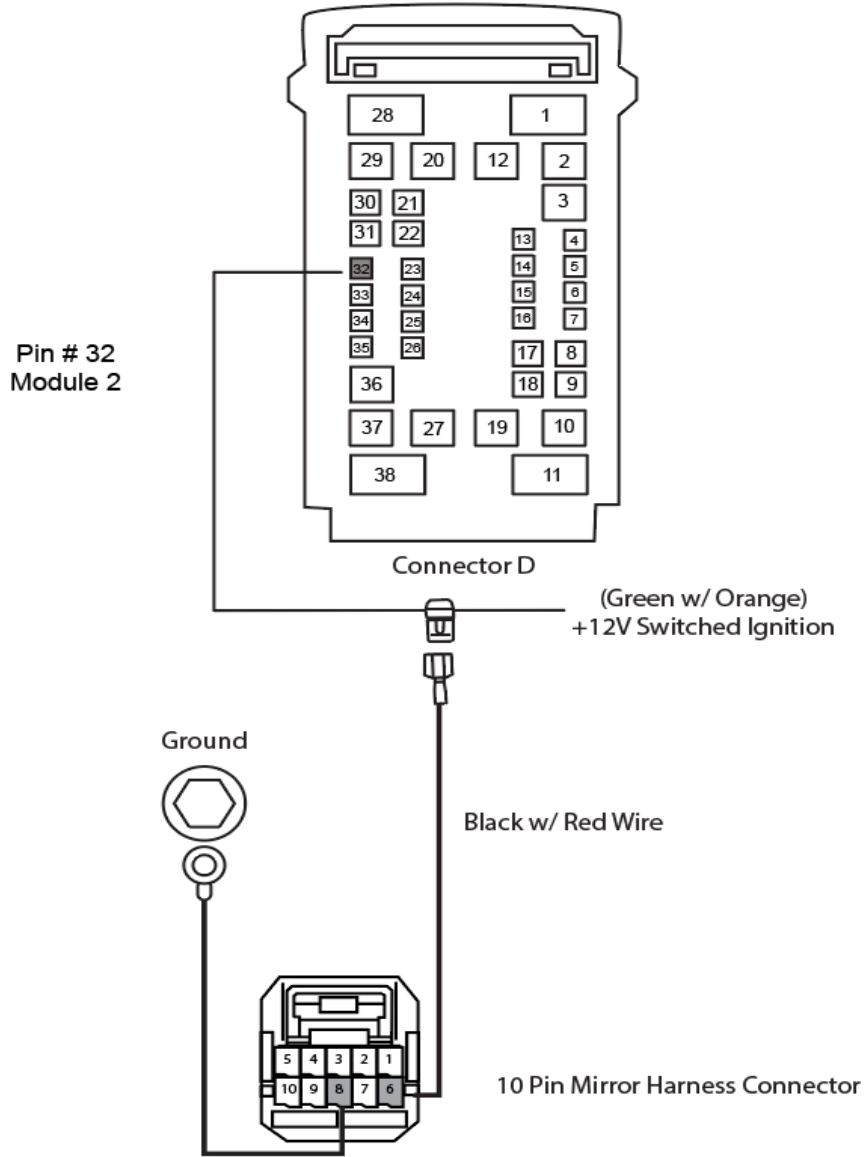

No	Gauge	Color	Function	Circuit	Fuse
1					
2					
3					
4					
5					
6	22	BLK w/ RED	IG (switched power)	Power Dist.	Module 2 (10 amp)
7					
8	22	BLK	GND		
9					
10					

