

Genuine Accessories



Vehicle Model **Santa Fe Sport**

Model Year 2017~
 Part No. 2WF46 AC650
 Language English
 Rev. Date 11/23/2015

Accessory: **Front Mudguard Kit**

Difficulty: B

Note: Difficulty stated above reflects the minimum level of expertise required to install the accessory:
 (A) Customer
 (B) Dealer Technician
 (C) Master Technician or Specialist

Instructional Symbols / Definitions

	Denotes warnings that may lead to serious physical injury or vehicle damage		Denotes quality processes to be checked prior to moving to the next step	Denotes personal protective equipment (PPEs) that may be required for a step. Examples of safety equipment icons noted below:	
	Denotes cautions to be taken to avoid physical injury or electronic component damage		Denotes specific tools that are necessary to complete a step		
	Denotes cautions to be taken to avoid vehicle and component damage	N O T E	Denotes important information to be reviewed during the step		
				Glasses	Gloves
				Mask	Hearing Protection

Basic Required Tools

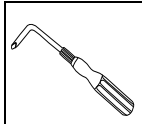

Right Angle #2 Phillips Screwdriver

Part Weight (Gross)

0.82	lbs
0.37	kg

All dealers must determine if the weight they have added in the form of all options or accessories, when added to the weight of all Port/Dealer Installed options or accessories, exceeds the lesser of 1.5% of GVWR or 100 lbs. If the additional weight does exceed the lesser of the indicated thresholds, a "Load Carrying Capacity Reduced" label must be installed. A black, fine-point, indelible marker must be used to write by hand onto the label, the reduced carrying capacity in kilograms or pounds, which is the total weight of all added options and accessories.

Notes to the installer:

- 1 Read the entire Installation Instructions prior to beginning the installation of the part.
- 2 Make sure the vehicle is completely clean and dry in the area(s) the part is to be installed.
- 3 Ensure the vehicle is properly protected in the area(s) that the accessory is to be installed.
- 4 NEVER place tools on painted surfaces, seating surfaces, dash pad, console or floor carpet/mats.
- 5 Always wear appropriate personal protective equipment, including gloves, safety glasses, etc., when required.

Kit Overview

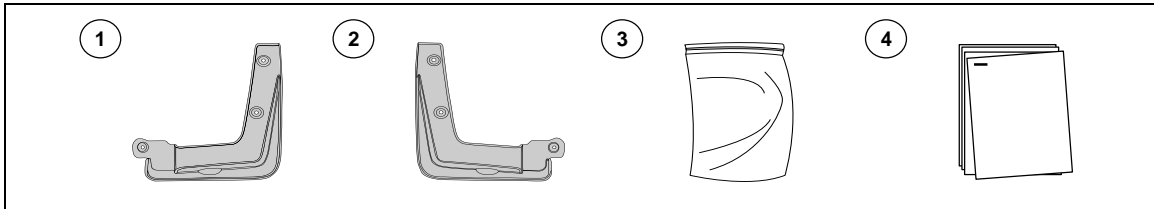





No.	Qty	Description
1	1	Front Mudguard (LH)
2	1	Front Mudguard (RH)
3	1	Hardware Bag
4	1	Installation Instructions



Hardware Kit Contents

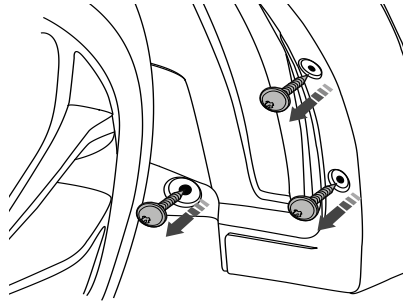

A	
6	Self Tapping Screw M6x25

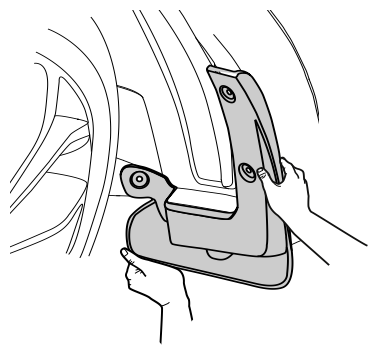

Hardware Total
6

Genuine Accessories

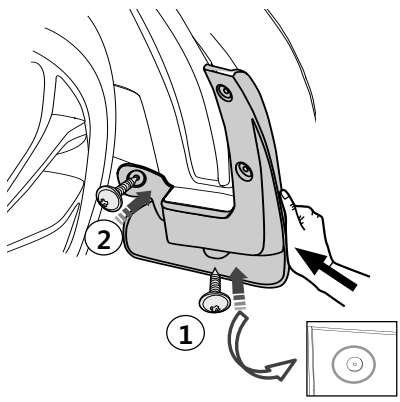
1	 Right Angle #2 Phillips Screwdriver
	
	
	
N O T E	1. Remove the three (3) M6x20 screws as shown. Save one (1) M6x20 screw for reuse in step 3. 2. Discard the other two (2) M6x20 screws.

2	
	
N O T E	1. Align the mudguard as shown ensuring a proper fit.
 Make sure to push the mudguard upward and in during the installation to eliminate any possible gaps.	

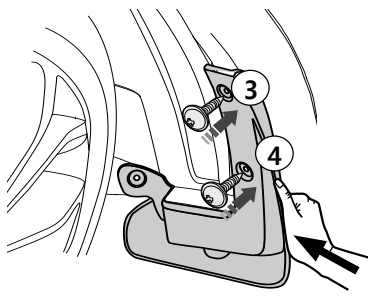
3	 Right Angle #2 Phillips Screwdriver
	
N O T E	1. While pushing the mudguard upward and in as shown in the drawing, insert and fasten one (1) M6x20 screw saved from step 1, through the bottom of the mudguard and into the center of the dimple on the underside of the vehicle. 2. Insert and fasten one (1) provided M6x25 screw into the inboard hole as shown.
 Make sure to push the mudguard upward and in during the installation to eliminate any possible gaps.	

4	 Right Angle #2 Phillips Screwdriver
	
N O T E	1. While pushing the mudguard upward and in as shown in the drawing, insert and fasten one (1) provided M6x25 screw into the upper hole as shown. 2. Insert and fasten one (1) provided M6x25 screw into the lower hole as shown. 3. Repeat steps 1-4 for the opposite side. 4. Installation is complete.
 After the installation, check for any visible gaps. If any gap exceeds 0.5mm, loosen the mounting screws and refit the Front Mudguard to the body to achieve the correct specification. Be careful not to over-tighten or strip the screw head.	

Visual Check	Item to be Checked
	Make sure the Front Mudguard is properly aligned to the vehicle.

Result	
Front Mudguard is properly aligned.	