

Genuine Accessories



Vehicle Model **G80**

Model Year 2017-
 Part No. B1F46 AK100
B1F46 AU200
 Language English
 Rev. Date 8/10/2016

Accessory: **Rear Mudguards**

Difficulty: (B)

Note: Difficulty stated above reflects the minimum level of expertise required to install the accessory:
 (A) Customer
 (B) Dealer Technician
 (C) Master Technician or Specialist

Instructional Symbols / Definitions

	Denotes warnings that may lead to serious physical injury or vehicle damage		Denotes quality processes to be checked prior to moving to the next step	Denotes personal protective equipment (PPEs) that may be required for a step. Examples of safety equipment icons noted below:	
	Denotes cautions to be taken to avoid physical injury or electronic component damage		Denotes specific tools that are necessary to complete a step		Glasses
	Denotes cautions to be taken to avoid vehicle and component damage	N O T E	Denotes important information to be reviewed during the step		Gloves
					Mask
					Hearing Protection

Basic Required Tools

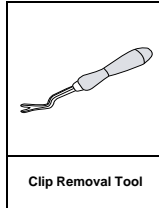
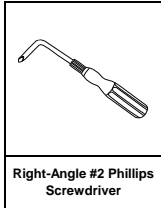

Part Weight (Gross)

0.35	lbs
0.16	kg

FMVSS 110 Compliance Information

All dealers must determine if the weight they have added in the form of all options or accessories, when added to the weight of all Port/Dealer Installed options or accessories, exceeds the lesser of 1.5% of GVWR or 100 lbs. If the additional weight does exceed the lesser of the indicated thresholds, a "Load Carrying Capacity Reduced" label must be installed. A black, fine-point, indelible marker must be used to write by hand onto the label, the reduced carrying capacity in kilograms or pounds, which is the total weight of all added options and accessories.
Load Label Part Number: NP070 - 09003

Notes to the installer:

- 1 Read the entire Installation Instructions prior to beginning the installation of the part.
- 2 Make sure the vehicle is completely clean and dry in the area(s) the part is to be installed.
- 3 Ensure the vehicle is properly protected in the area(s) that the accessory is to be installed.
- 4 NEVER place tools on painted surfaces, seating surfaces, dash pad, console or floor carpet/mats.
- 5 Always wear appropriate personal protective equipment, including gloves, safety glasses, etc., when required.

Genuine Accessories

Kit Overview

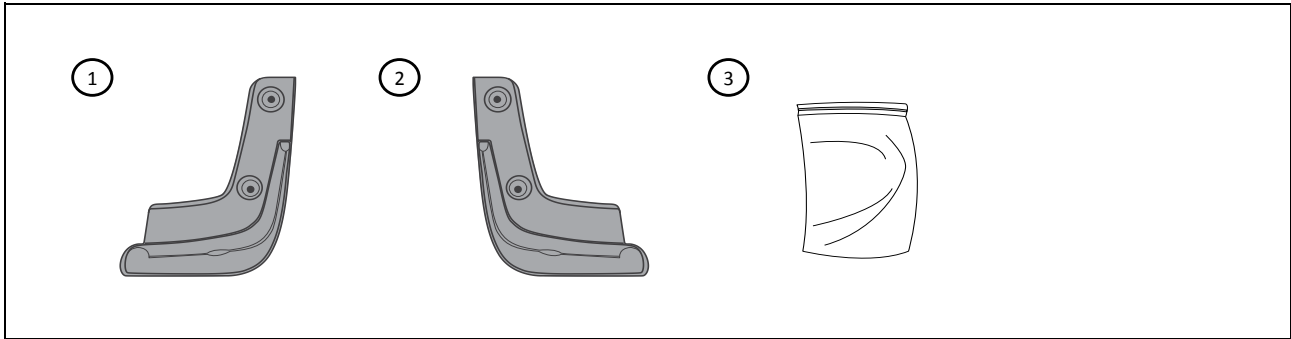

No.	Qty	Description
1	1	Rear Mudguard (LH)
2	1	Rear Mudguard (RH)
3	1	Hardware Bag

Hardware Kit Contents



A	
4	Tapping Screw



B	
2	Plastic Retainer

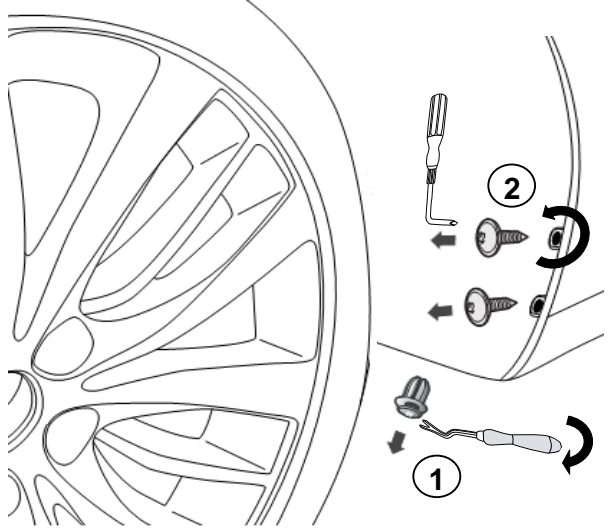

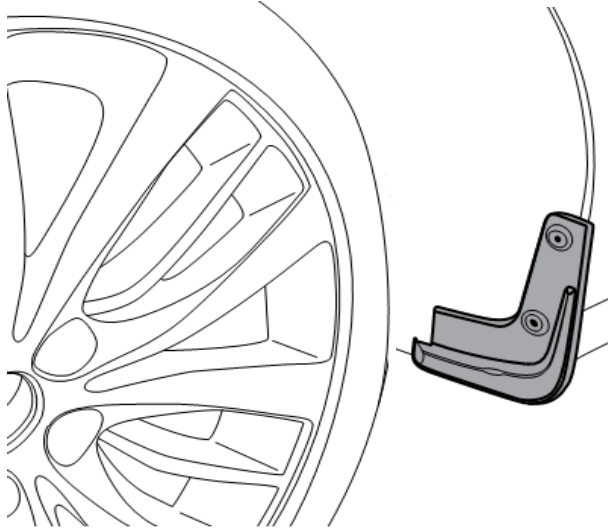
Hardware Total
6

Genuine Accessories

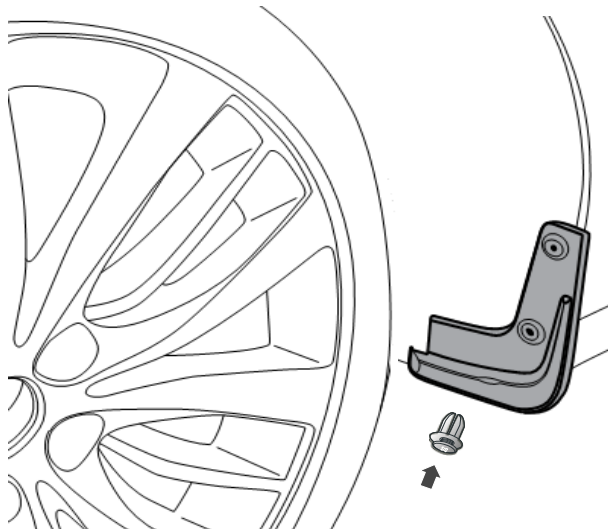
1		Right-Angle #2 Phillips Screwdriver and Clip Removal Tool
		
N O T E	<ol style="list-style-type: none"> 1. Release the center portion of one (1) Plastic Retainer and remove the Plastic Retainer from the vehicle as shown. 2. Remove the two (2) Screws from the highlighted areas as shown. 3. Discard the removed hardware. 	

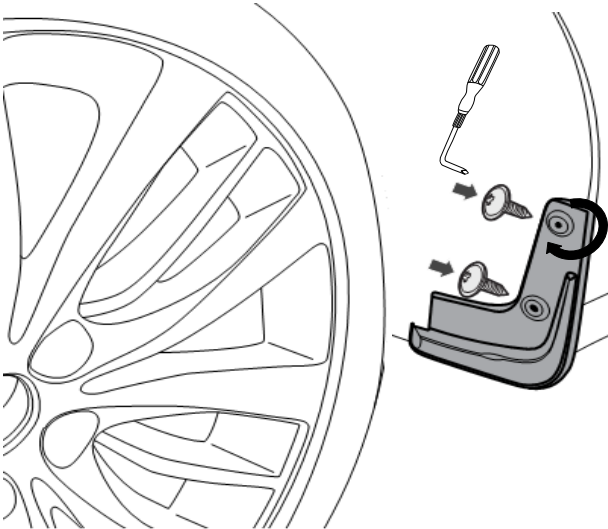

2		
		
N O T E	<ol style="list-style-type: none"> 1. Align the Rear Mudguard as shown ensuring a proper fit. 	
	<p>Make sure to push the Rear Mudguard upward and in during the installation to eliminate any possible gaps.</p>	

3		
		
N O T E	<ol style="list-style-type: none"> 1. Insert one (1) Plastic Retainer into the underside hole. Make sure to push in the center portion of the retainer to lock the retainer in place. 	
	<p>Make sure to push the Rear Mudguard upward and in during the installation to eliminate any possible gaps.</p>	

4		Right-Angle #2 Phillips Screwdriver
		
N O T E	<ol style="list-style-type: none"> 1. While pushing the Rear Mudguard up and in, insert and fasten two (2) Self Tapping Screws into the holes as shown. 2. Repeat steps 1 - 4 for the opposite side. 3. Installation is complete. 	
	<p>After the installation, check for any visible gaps. If any gap exceeds 0.5mm, loosen the mounting screws and refit the Rear Mudguard to the body to achieve the correct specification. Be careful not to over-tighten or strip the head of the screw.</p>	

Genuine Accessories

Visual Check

Item to be Checked		Result	
	Make sure to push the Rear Mudguard upward and in during the installation to eliminate any possible gaps.	Any visible gaps should not exceed 0.5mm.	
	After the installation, check for any visible gaps. If any gap exceeds 0.5mm, loosen the mounting screws and refit the Rear Mudguard to the body to achieve the correct specification.	Any visible gaps should not exceed 0.5mm.	