

Genuine Accessories



Vehicle Model: Tucson
Model Year: 2019~
Part No.: D3F46 AK150
Language: English
Rev. Date: 7/25/2018

Accessory: Rear Mudguards
Difficulty: (B)

Note: Difficulty stated above reflects the minimum level of expertise required to install the accessory:
 (A) Customer
 (B) Dealer Technician
 (C) Master Technician or Specialist

Instructional Symbols / Definitions

| | | | | | |
|--|--|----------------------------|--|---|--------------------|
| | Denotes warnings that may lead to serious physical injury or vehicle damage | | Denotes quality processes to be checked prior to moving to the next step | Denotes personal protective equipment (PPEs) that may be required for a step. Examples of safety equipment icons noted below: | |
| | Denotes cautions to be taken to avoid physical injury or electronic component damage | | Denotes specific tools that are necessary to complete a step | | |
| | Denotes cautions to be taken to avoid vehicle and component damage | N O T E | Denotes important information to be reviewed during the step | | |
| | | | | Glasses | Gloves |
| | | | | Mask | Hearing Protection |

Basic Required Tools

| | |
|-------------------------------------|-------------------|
| | |
| Right Angle #2 Phillips Screwdriver | Clip Removal Tool |

Part Weight (Gross)

| | |
|-------------|-----|
| 0.64 | lbs |
| 0.29 | kg |

FMVSS 110 Compliance Information

All dealers must determine if the Net weight they have added in the form of all options or accessories, when added to the weight of all Port/Dealer Installed options or accessories, exceeds the lesser of 1.5% of GVWR or 100 lbs. If the additional weight does exceed the lesser of the indicated thresholds, a "Load Carrying Capacity Reduced" label must be installed. A black, fine-point, indelible marker must be used to write by hand onto the label, the reduced carrying capacity in kilograms or pounds, which is the total weight of all added options and accessories.
Load Label Part Number: NP070 - 09003

Notes to the installer:

- 1) Read the entire Installation Instructions prior to beginning the installation of the part.
- 2) Make sure the vehicle is completely clean and dry in the area(s) the part is to be installed.
- 3) Ensure the vehicle is properly protected in the area(s) that the accessory is to be installed.
- 4) NEVER place tools on painted surfaces, seating surfaces, dash pad, console or floor carpet/mats.
- 5) Always wear appropriate personal protective equipment, including gloves, safety glasses, etc., when required.

Genuine Accessories

Kit Overview

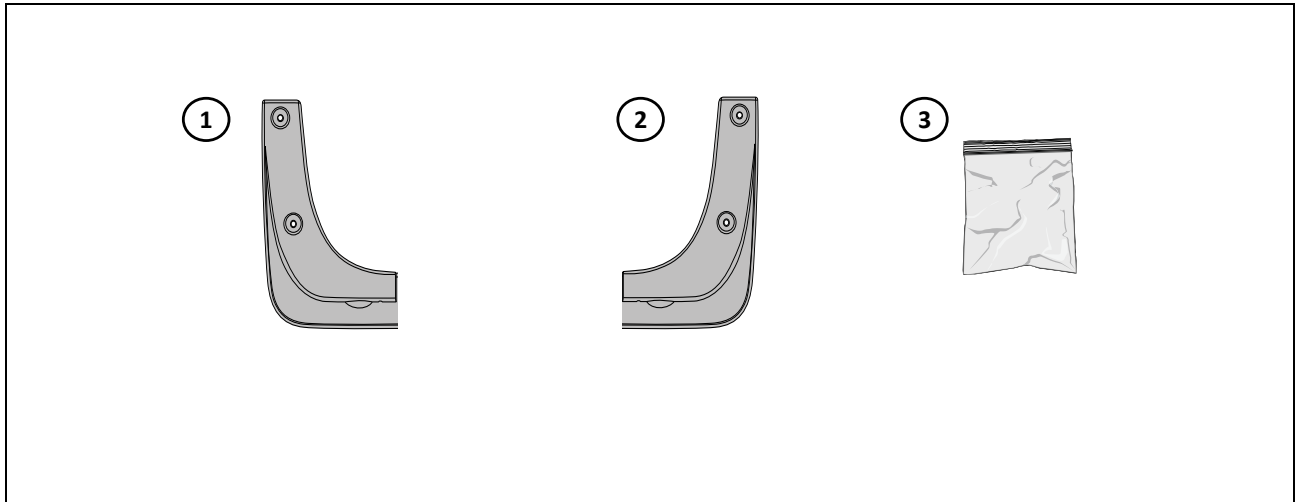



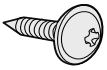
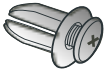

| No. | Qty | Description |
|-----|-----|------------------|
| 1 | 1 | Rear Mudguard LH |
| 2 | 1 | Rear Mudguard RH |
| 3 | 1 | Hardware Bag |

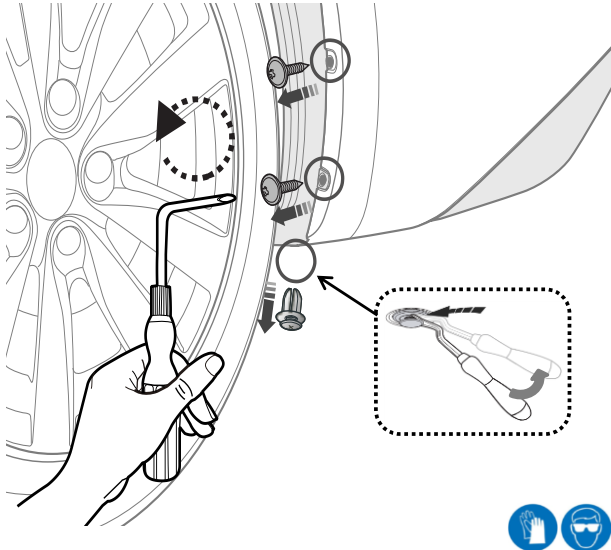

Hardware Kit Contents

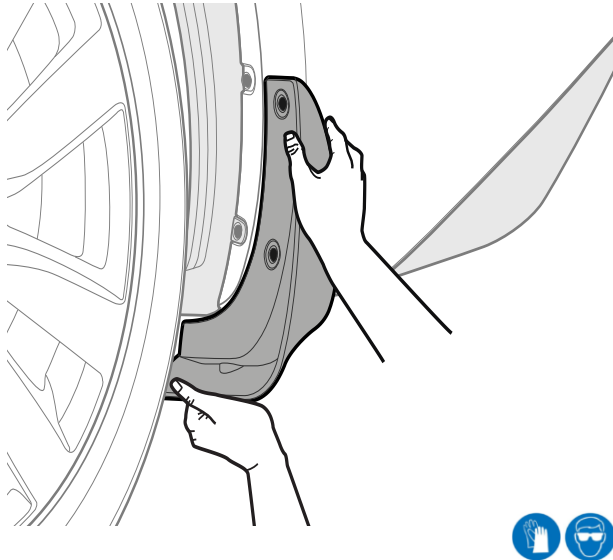

| | | | |
|---|---|---|---|
| A |  | B |  |
| 4 | Tapping Screw | 2 | Plastic Retainer |

| |
|--------------------|
| Hardware Kit Total |
| 6 |

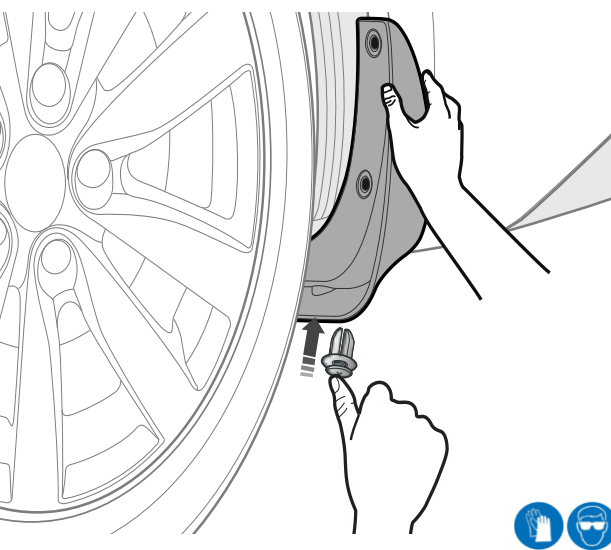
| | | |
|---|--|---|
| 1 |  | Right Angle #2 Phillips Screwdriver and Clip Removal Tool |
|  | | |
| N O T E | <p>A. Starting on the driver's side rear wheel well area, remove the plastic retainer from the bottom of vehicle as shown.</p> <p>B. Remove the two (2) screws as shown.</p> <p>C. Discard the removed hardware.</p> | |

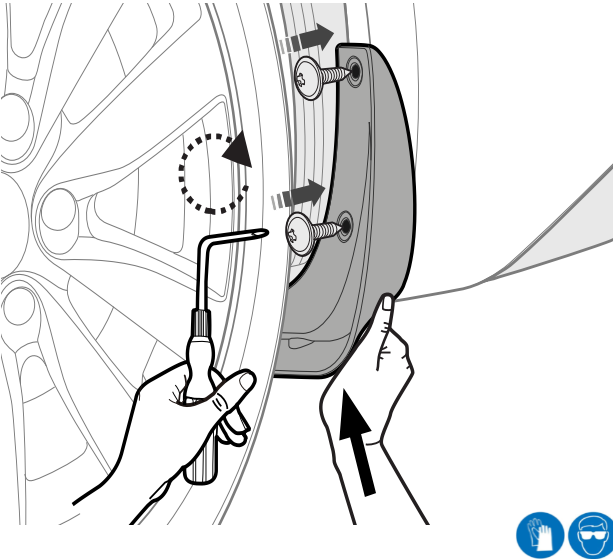

| | | |
|--|---|--|
| 2 |  | |
|  | | |
| N O T E | <p>A. Align the rear mudguard (LH) as shown ensuring a proper fit.</p> | |
|  | <p>Make sure to push the mudguard upward and inward during the installation to eliminate any possible gaps.</p> | |

| | | |
|---|--|--|
| 3 |  | |
|  | | |
| N O T E | <p>A. Insert one (1) provided retainer into the bottom hole as shown. Make sure to push in the center portion of the plastic retainer to lock the retainer in place.</p> | |
|  | <p>Make sure to push the mudguard upward and inward during the installation to eliminate any possible gaps.</p> | |

| | | |
|--|--|-------------------------------------|
| 4 |  | Right Angle #2 Phillips Screwdriver |
|  | | |
| N O T E | <p>A. While pushing the mudguard upward and inward as shown, insert and fasten two (2) provided screws as shown.</p> <p>B. Repeat steps 1-4 for passenger's side rear mudguard (RH).</p> <p>C. Installation is complete.</p> | |
|  | <p>Check for any visible gaps. If any gaps exceed 0.5mm, loosen the mounting screws and refit the mudguard(s) to the body to decrease or eliminate the gaps. Be careful not to over-tighten or strip the screw head.</p> | |

Genuine Accessories

Visual Check

| Item to be Checked | | Result | |
|---|--|---------------------------------------|--|
|  | Make sure to push the Rear Mudguards upward and inward during the installation to eliminate any possible gaps. | Rear Mudguards are properly aligned. | |
|  | Check for any visible gaps. If any gaps exceed 0.5mm, loosen the mounting screws and refit the mudguard(s) to the body to decrease or eliminate the gaps. | Any visible gaps do not exceed 0.5mm. | |