

Genuine Accessories



Vehicle Model: Multiple

Model Year 2018~

Part No. G3F66 AC000

Language English

Rev. Date 3/1/2019

Accessory: Glove Box Stopper Light

Difficulty: (B)

Note: Difficulty stated above reflects the minimum level of expertise required to install the accessory:

- (A) Customer
- (B) Dealer Technician
- (C) Master Technician or Specialist

Electronic Installation Instructions

If this is a printed copy of the installation instructions, ensure you have the latest revision by scanning the QR code or by entering the website address listed below before beginning installation. Use the latest revision date as noted by "Rev. Date" above.

www.hyundaiaccessories.com/admin_media_uploads/installationSheets/g3f66_ac000.pdf

Instructional Symbols / Definitions

<p>Denotes warnings that may lead to serious physical injury or vehicle damage</p>	<p>Denotes quality processes to be checked prior to moving to the next step</p>	<p>Denotes personal protective equipment (PPEs) that may be required for a step. Examples of safety equipment icons noted below:</p>
<p>Denotes cautions to be taken to avoid physical injury or electronic component damage</p>	<p>Denotes specific tools that are necessary to complete a step</p>	<p>Glasses</p>
<p>Denotes cautions to be taken to avoid vehicle and component damage</p>	<div style="border: 1px solid black; padding: 2px; text-align: center; width: 20px; margin: 0 auto;"> N O T E </div> <p>Denotes important information to be reviewed during the step</p>	<p>Gloves</p>
		<p>Mask</p>
		<p>Hearing Protection</p>

Basic Required Tools

<p>#0 Phillips Screwdriver</p>	<p>50/50 Isopropyl Alcohol (70%) & Water</p>	<p>Clean Cloth</p>
---------------------------------------	---	---------------------------

Part Weight (Gross)

0.07	lbs
0.03	kg

FMVSS 110 Compliance Information

All dealers must determine if the Net weight they have added in the form of all options or accessories, when added to the weight of all Port/Dealer Installed options or accessories, exceeds the lesser of 1.5% of GVWR or 100 lbs. If the additional weight does exceed the lesser of the indicated thresholds, a "Load Carrying Capacity Reduced" label must be installed. A black, fine-point, indelible marker must be used to write by hand onto the label, the reduced carrying capacity in kilograms or pounds, which is the total weight of all added options and accessories.

Load Label Part Number: NP070 - 09003

Notes to the installer:



- 1) Read the entire Installation Instructions prior to beginning the installation of the part.
- 2) Make sure the vehicle is completely clean and dry in the area(s) the part is to be installed.
- 3) Ensure the vehicle is properly protected in the area(s) that the accessory is to be installed.
- 4) NEVER place tools on painted surfaces, seating surfaces, dash pad, console or floor carpet/mats.
- 5) Always wear appropriate personal protective equipment, including gloves, safety glasses, etc., when required.
- 6) **NOTE: Do not remove the "Notice" hang tag. This is to be removed by the customer only.**

Kit Overview



<div style="border: 1px solid black; border-radius: 50%; width: 30px; height: 30px; display: flex; align-items: center; justify-content: center; margin: 0 auto;">1</div>	<div style="border: 1px solid black; border-radius: 50%; width: 30px; height: 30px; display: flex; align-items: center; justify-content: center; margin: 0 auto;">2</div>	<div style="border: 1px solid black; border-radius: 50%; width: 30px; height: 30px; display: flex; align-items: center; justify-content: center; margin: 0 auto;">3</div>	<div style="border: 1px solid black; border-radius: 50%; width: 30px; height: 30px; display: flex; align-items: center; justify-content: center; margin: 0 auto;">4</div> <div style="border: 1px solid black; padding: 5px; margin: 10px auto; width: 80%;">Quick Reference Guide</div>
---	---	---	--

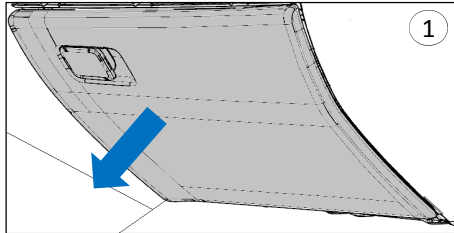
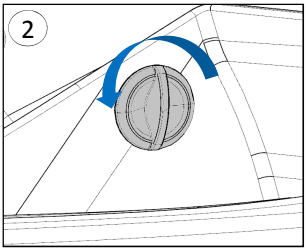
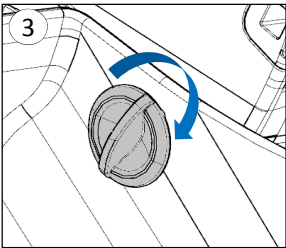

No.	Qty	Description
1	1	Glove Box Stopper Light
2	1	Magnetic Bracket
3	2	M2 Screw
4	1	Quick Reference Guide

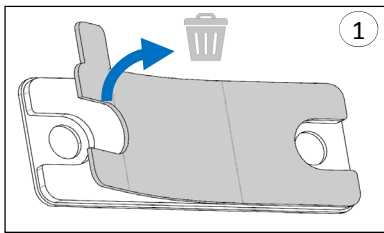
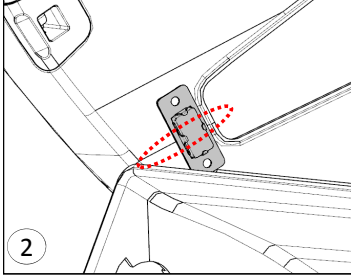
Genuine Accessories

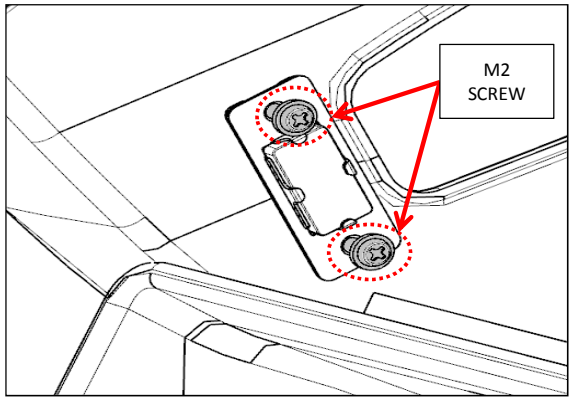
1		
		
 		
NOTE	<p>A. Open the Glove Box and remove contents. B. Rotate the left stopper counterclockwise and remove & discard. C. Rotate the right stopper clockwise and remove. Save for reinstallation. D. Disconnect the Glove Box Damper Linkage, if applicable.</p>	
 Store the removed parts in a safe location.		

2		50/50 Isopropyl Alcohol (70%) & Water and a Clean Cloth
		
		
NOTE	<p>A. Fully lower the Glove Box. B. Using 50/50 Isopropyl Alcohol (70%) & Water and a Clean Cloth, clean the dash panel area to the left of the Glove Box opening where the Magnetic Bracket will be installed. Allow to fully dry. C. Remove the adhesive liner from the Magnetic Bracket. D. Attach the Magnetic Bracket to the edge of the slot at the Glove Box opening. Make sure to center the Magnetic Bracket with the molded line of the dash panel as shown, if applicable.</p>	

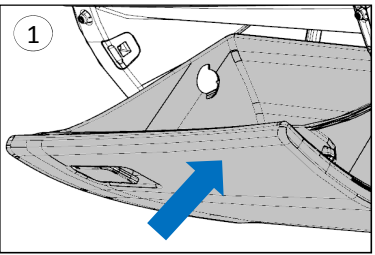
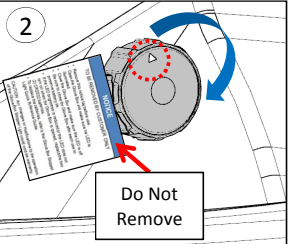
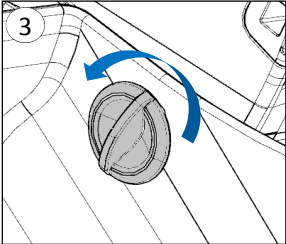
3		#0 Phillips Screwdriver
		
NOTE	<p>A. Using two (2) M2 Screws, insert the screws through the Magnetic Bracket holes and into the dash panel. Carefully tighten the screws until they just set. Do not over-tighten.</p>	
 Do not damage the Glove Box or Dash Panel. Do not over-tighten screws.		

4		
		
 		
NOTE	<p>NOTE: Do not remove the "NOTICE" hang tag. This is to be removed by the customer only. A. Slightly raise the glovebox. B. Insert the Glove Box Stopper Light into the left side of the glove box, and rotate clockwise. Make sure the triangular shape is upwards after it is installed. C. Insert the right stopper removed in step 1 into the right side of the Glove Box and rotate counterclockwise. D. Reinstall the Glove Box Damper Linkage, if applicable. E. Place contents removed in step 1 and the provided quick reference guide, into the Glove Box. F. A function check cannot be performed with the "NOTICE" hang tag installed. Do not remove the "NOTICE" hang tag.</p>	
 NOTE: The "NOTICE" hang tag must remain in place to ensure the batteries are fresh when delivered to the customer. Therefore, no testing can be completed at this time.		