

Genuine Accessories



Vehicle Model Veloster

Model Year 2019~
 Part No. J3F05 AK400
 Language English
 Rev. Date 4/4/2018

Accessory: Pedal Kit (AT)

Difficulty: B

Note: Difficulty stated above reflects the minimum level of expertise required to install the accessory:

- (A) Customer
- (B) Dealer Technician
- (C) Master Technician or Specialist

Instructional Symbols / Definitions

| | | | | | |
|--|--|----------------------------|--|---|--|
| | Denotes warnings that may lead to serious physical injury or vehicle damage | | Denotes quality processes to be checked prior to moving to the next step | Denotes personal protective equipment (PPEs) that may be required for a step. Examples of safety equipment icons noted below: | |
| | Denotes cautions to be taken to avoid physical injury or electronic component damage | | Denotes specific tools that are necessary to complete a step | | |
| | Denotes cautions to be taken to avoid vehicle and component damage | N O T E | Denotes important information to be reviewed during the step | | |

Basic Required Tools

| | | | | |
|---------|-------------|----------------------|---------------|-----------|
| | | | | |
| Ratchet | 10mm Socket | 12mm Deepwell Socket | Torque Wrench | Extension |

FMVSS 110 Compliance Information

All dealers must determine if the weight they have added in the form of all options or accessories, when added to the weight of all Port/Dealer Installed options or accessories, exceeds the lesser of 1.5% of GVWR or 100 lbs. If the additional weight does exceed the lesser of the indicated thresholds, a "Load Carrying Capacity Reduced" label must be installed. A black, fine-point, indelible marker must be used to write by hand onto the label, the reduced carrying capacity in kilograms or pounds, which is the total weight of all added options and accessories.
 Load Label Part Number: NP070 - 09003

Notes to the installer:

- 1 Read the entire Installation Instructions prior to beginning the installation of the part.
- 2 Make sure the vehicle is completely clean and dry in the area(s) the part is to be installed.
- 3 Ensure the vehicle is properly protected in the area(s) that the accessory is to be installed.
- 4 NEVER place tools on painted surfaces, seating surfaces, dash pad, console or floor carpet/mats.
- 5 Always wear appropriate personal protective equipment, including gloves, safety glasses, etc., when required.





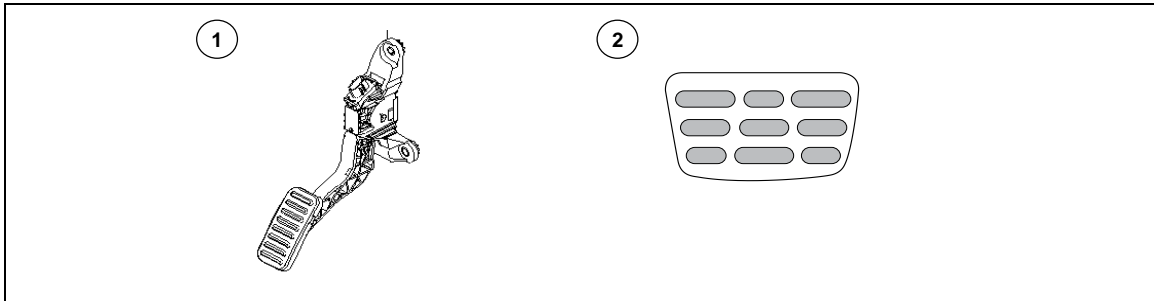



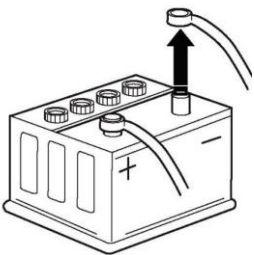

| | | |
|---------------------|-------------|-----|
| Part Weight (Gross) | 1.00 | lbs |
| | 0.45 | kg |

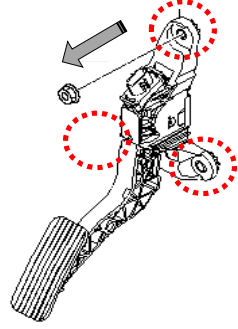
Kit Overview



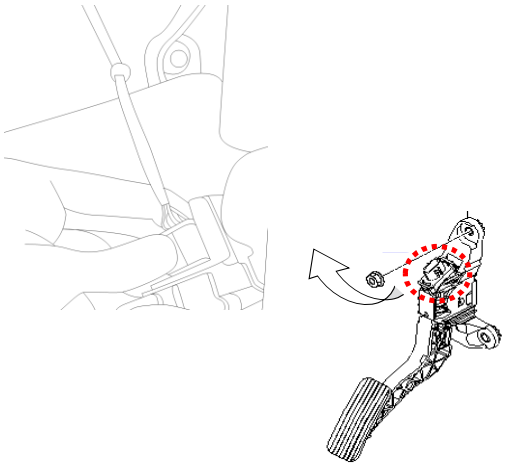

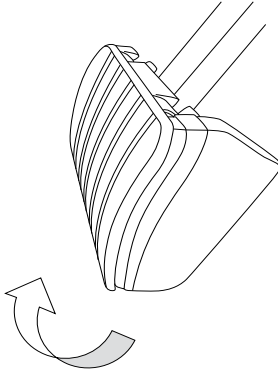
| No. | Qty | Description |
|-----|-----|----------------------------|
| 1 | 1 | Accelerator Pedal Assembly |
| 2 | 1 | Brake Pedal Pad |

Genuine Accessories



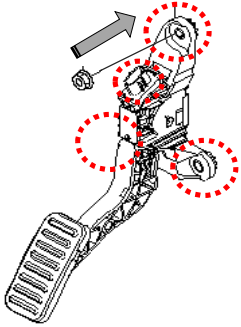

| | | |
|---|---|--|
| 1 |  | 10mm Socket and Ratchet |
|  | | |
| N O T E | A. Disconnect and isolate vehicle's negative battery cable. | |
|  | | |
| <p>WARNING! Shock Hazard. Do not touch vehicle's negative battery terminal to vehicle's positive battery terminal. Serious injury and damage to the vehicle may occur.</p> | | |
| 2 |  | 12mm Deepwell Socket, Extension, and Ratchet |
|  | | |
|   | | |
| N O T E | <p>A. Temporarily remove the floor mat for better accessibility. B. Remove the three (3) M8 nuts from the OEM accelerator pedal assembly using a 12mm deepwell socket. C. Save the nuts for re-installation.</p> | |
|  | | |
| <p>Be careful not to drop the nuts under the factory carpet.</p> | | |
| 3 |  | |
|  | | |
| N O T E | <p>A. Disconnect the connector from the OEM accelerator pedal by pressing the side release tab, and pulling up and away from accelerator pedal as indicated by the arrow. B. Carefully remove the OEM accelerator pedal assembly from the vehicle.</p> | |
|  | | |
| <p>Be careful not to damage the wire harness or connector when removing.</p> | | |
| 4 |  | |
|  | | |
|   | | |
| N O T E | A. Detach the OEM rubber brake pedal pad from the brake pedal and discard. | |

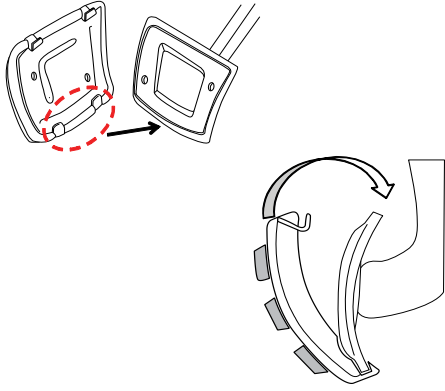
Genuine Accessories

| | | |
|---|--|---|
| 5 |  | 12mm Deepwell Socket, Extension, Ratchet, and Torque Wrench |
|  | | |
| Torque: 12.8 ~ 15.7 N.m (1.3 ~ 1.6 kgf.m, 9.4 ~ 11.6 lb-ft) | | |
| N O T E | A. Install the accessory accelerator pedal onto the three (3) M8 studs on the bulkhead. B. Install the three (3) M8 nuts removed in step 2. C. Torque the nuts to 12.8 ~ 15.7 N.m (1.3 ~ 1.6 kgf.m, 9.4 ~ 11.6 lb-ft). D. Reinstall the connector into the accessory accelerator pedal making sure it locks into place. | |
|  | Make sure the connector is fully locked into the accessory accelerator pedal socket. | |

| | | |
|--|---|---|
| 6 |  | 10mm Socket, Extension, Ratchet and Torque Wrench |
|  | | |
| N O T E | A. Engage lower hooks of accessory brake pad onto the lower part of the brake pedal. B. Rotate pad upwards and apply pressure to the upper part of the accessory brake pad until an audible 'click' is heard. C. Remove the protective film. D. Reinstall the negative battery cable. E. Torque the cable to 5.0 ~ 6.0 N.m (0.5 ~ 0.6 kgf.m, 3.7 ~ 4.4 lb-ft) | |

Visual Check

| | Item to be Checked |
|---|---|
|  | Do not leave the 10mm socket or ratchet in the engine compartment or on the battery after removing the negative battery cable. |
|  | Check that the accelerator pedal functions as intended. Start vehicle, keep the gear selector in park, and apply gentle pressure to the accelerator pedal. Do NOT test drive the vehicle. |
|  | Make sure all three (3) M8 nuts are torqued. |
|  | Make sure the connector is fully locked into the accessory accelerator pedal socket. |

| | Result |
|--|--|
| | 10mm socket or ratchet is not in engine compartment or on battery. |
| | Accessory accelerator pedal does not bind and operates smoothly. |
| | Three (3) M8 nuts are torqued. |
| | Electrical connector locked into accessory accelerator pedal socket. |