

Genuine Accessories



Vehicle Model: Kona
Model Year: 2018~
Part No.: J9F22 AU000
Language: English
Rev. Date: 11/15/2017

Accessory: Door Visor
Difficulty: (B)

Note: Difficulty stated above reflects the minimum level of expertise required to install the accessory.
 (A) Customer
 (B) Dealer Technician
 (C) Master Technician

Instructional Symbols / Definitions

	Denotes warnings that may lead to serious physical injury or vehicle damage.		Denotes quality processes to be checked prior to moving to the next step.	Denotes safety equipment required to be used such as a mask, goggles, rubber gloves, and hearing protection.	
	Denotes cautions to be taken to avoid physical injury or electronic component damage.		Denotes specific tools that are necessary to complete the step.		
	Denotes cautions to be taken to avoid vehicle and component damage.	NOTE	Denotes instructional steps necessary to complete the process.		
				Mask	Goggles
				Rubber Gloves	Hearing Protection

Basic Required Tools

Soap & Water	50/50 Isopropyl Alcohol (70%) & Water	Ruler	Non-Permanent Marker or Pencil	Lint Free Cloth

Part Weight (Gross)

1.46	lbs
0.66	kg

FMVSS 110 Compliance Information

All dealers must determine if the weight they have added in the form of all options or accessories, when added to the weight of all Port/Dealer Installed options or accessories, exceeds the lesser of 1.5% of GVWR or 100 lbs. If the additional weight does exceed the lesser of the indicated thresholds, a "Load Carrying Capacity Reduced" label must be installed. A black, fine-point, indelible marker must be used to write by hand onto the label, the reduced carrying capacity in kilograms or pounds, which is the total weight of all added options and accessories.
 Load Label Part Number: NP070 - 09003

Notes to the installer:

- 1 Read the entire Installation Instructions prior to beginning the installation of the part.
- 2 Combine a mixture of 50/50 Isopropyl Alcohol (70%) & Water into a spray bottle.
- 3 Make sure the vehicle is completely clean and dry in the area(s) the part is to be installed.
- 4 Ensure the vehicle is properly protected in the area(s) that the accessory is to be installed.
- 5 NEVER place tools on painted surfaces, seating surfaces, dash pad, console or floor carpet/mats.
- 6 Always wear appropriate personal protective equipment, including gloves, safety glasses, etc., when required.
- 7 Adhesives used in this product are sensitive to temperature during installation, only install this product to the vehicle if the temperature is between 60°-80°F / 15°-27°C. Installing the parts to the vehicle outside of this temperature may lead to reduced level of performance.
- 8 Installation of all parts should not occur in direct sunlight or if the vehicle has been parked in direct sunlight and is hot as a result. Both the parts and vehicle should be at the same temperature 60°-80°F / 15°-27°C during the installation to ensure maximum adhesion.
- 9 Use of Door Visor may result in some wind noise heard.
- 10 Do not wash the vehicle for 48 hours after installation.
- 11 Do not drive the vehicle for 1 hour after installation.

Genuine Accessories

Kit Overview:

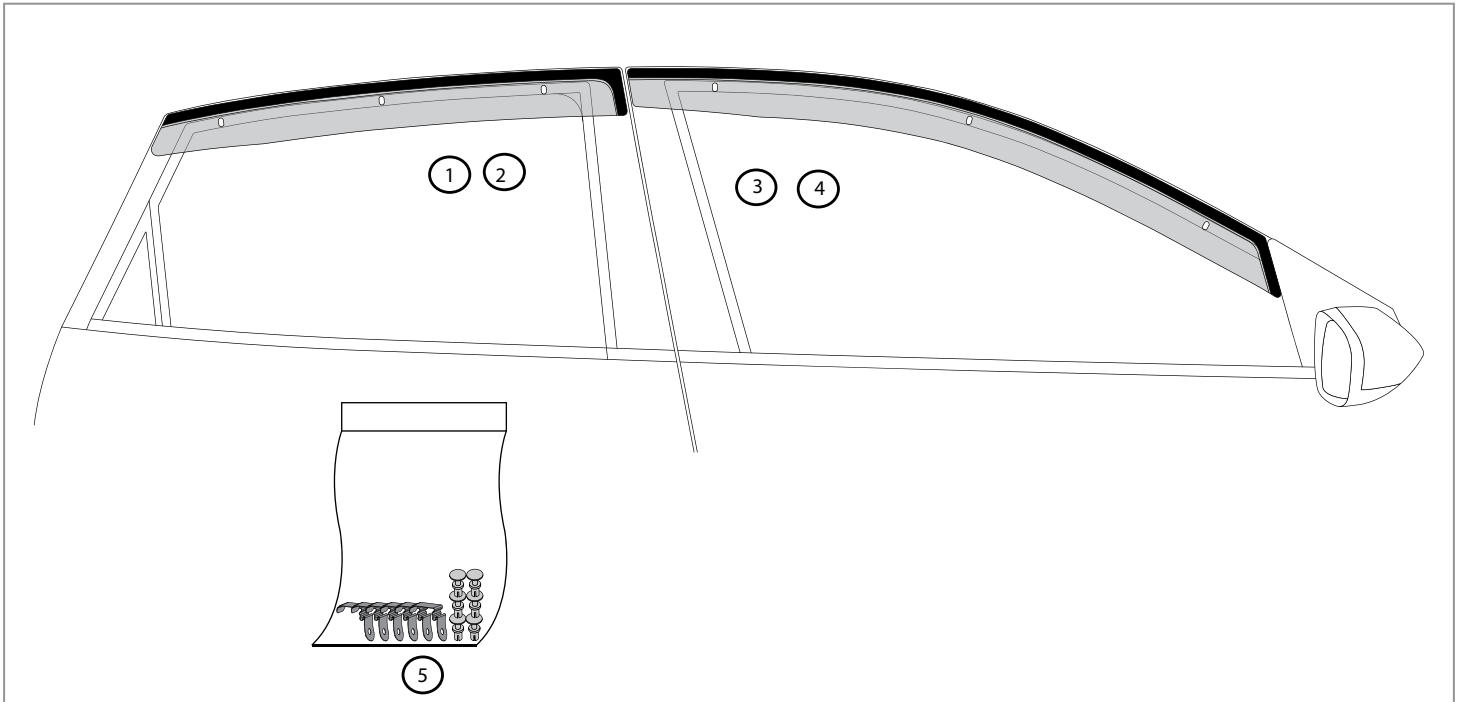

No.	Qty	Description
1	1	Rear RH Door Visor
2	1	Rear LH Door Visor
3	1	Front RH Door Visor
4	1	Front LH Door Visor
5	1	Hardware Kit

Hardware Overview:

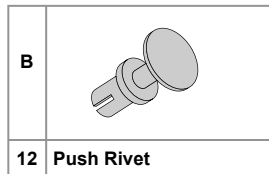
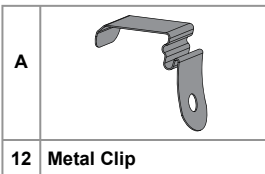

Hardware Total
24

Genuine Accessories

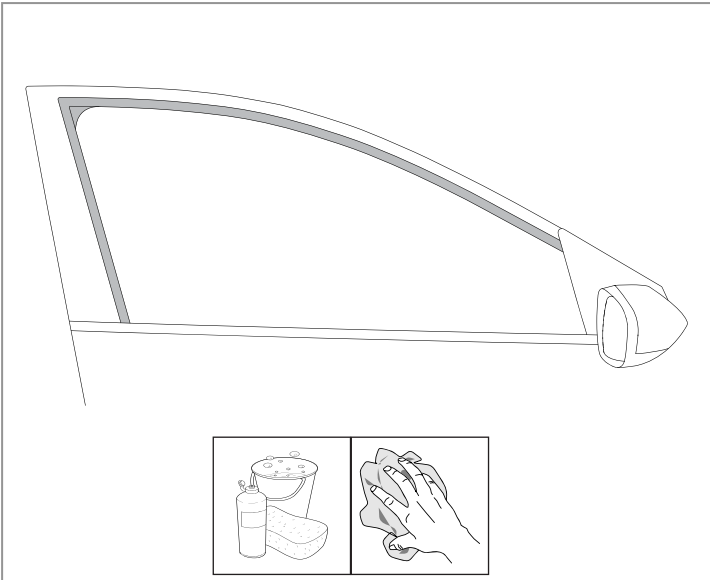

Wrench icon Soap and Water and Lint Free Cloth 1

NOTE
 A. Using Soap and Water, thoroughly clean the Front RH upper door frame and surrounding areas.
 B. Wipe away any residue with a Lint Free Cloth as shown.
 C. Lower the window.

Checkmark icon Make sure all surfaces are completely dry before trial fitting the Sport Visor.

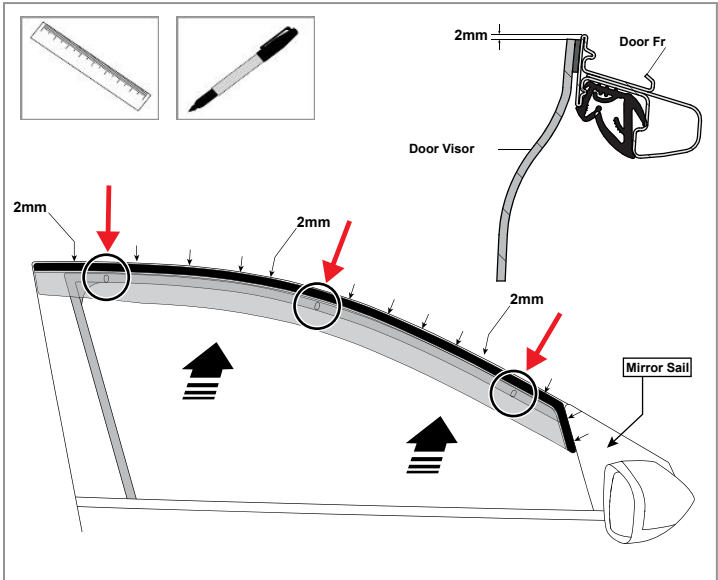

Wrench icon Non-Permanent Marker or Pencil and Ruler 2

NOTE
 A. Remove the protective film from the Door Visor.
 B. Trial fit the Front RH Sport Visor onto the door frame. Using a Ruler, align the top edge of the Sport Visor 2mm down from the top of the door edge, while locating the front edge of the Door Visor to the inside edge of the Mirror Sail.
 C. Using a Non-Permanent Marker or Pencil, mark the location of the three (3) holes in the Door Visor and where they correspond to the door frame, as shown.

Checkmark icon Make sure all surfaces are completely dry before proceeding to the next step.

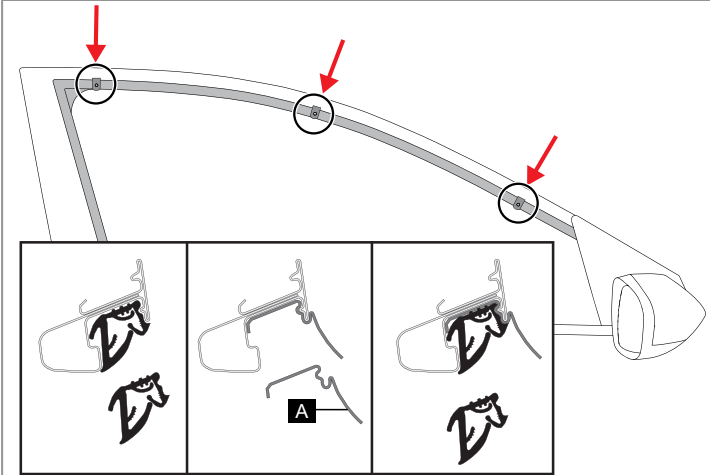

Wrench icon 3

NOTE
 A. From the center of the upper door frame, separate the rubber window seal from the door frame. Do not remove the rubber window seal from the front or rear corners of the upper door frame.
 B. Install one (1) metal clip "A" between the door frame and rubber window seal at the Front Marked Position.
 C. Install one (1) metal clip "A" between the door frame and rubber window seal at the Rear Marked Position.
 D. Install one (1) metal clip "A" between the door frame and rubber window seal at the Center Marked Position.
 E. Reinstall the rubber window seal into the door frame. Ensure that the rubber window seal is correctly seated.

Checkmark icon Ensure the rubber window seal is correctly seated. Be careful not to damage the rubber window seal.

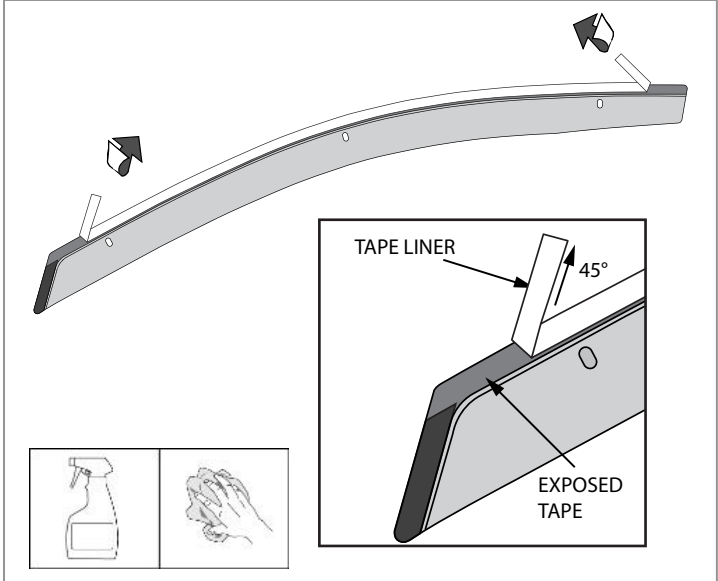

Wrench icon 50/50 Isopropyl Alcohol (70%) & Water and Lint Free Cloth 4

NOTE
 A. Using 50/50 Isopropyl Alcohol (70%) & Water and a lint free cloth, thoroughly clean the entire tape attachment area.
 - Make sure to remove any marks from the Non-Permanent Marker or Pencil.
 B. Peel back approximately 50mm (2") of the tape liner at each end and fold at 45° to the outside of the Door Visor as shown.

Checkmark icon Do not touch the exposed tape with hands, allow to get dirty or leave exposed for an extended period of time.

Genuine Accessories

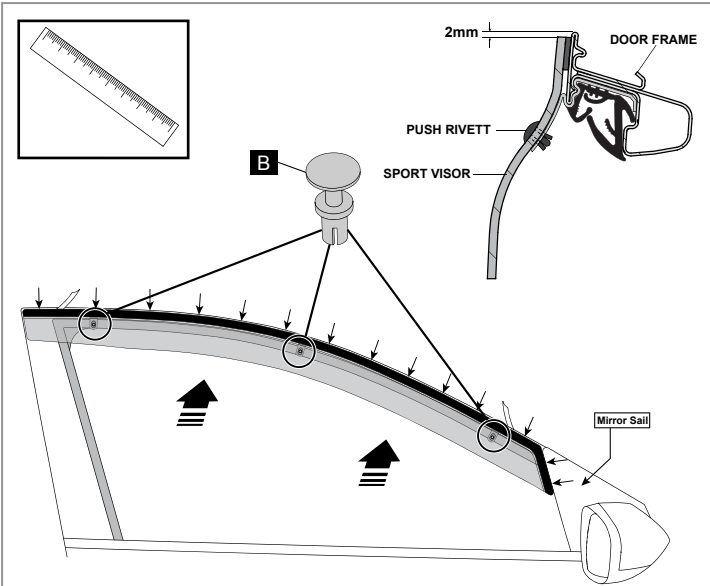

Ruler 5

- NOTE**
- A. Using a Ruler, align the top edge of the Door Visor 2mm below the top of the door edge while locating the front edge of the Sport Visor to the inside edge of the Mirror Sail.
 - B. Ensure the tape liners from step 4 are exposed.
 - C. Install three (3) push rivets "B" through the Door Visor into the three (3) metal clips, by pressing down on the center of the push rivet "B".

 Apply only light pressure to the front and rear corners of the Door Visor during the installation of the push rivets.

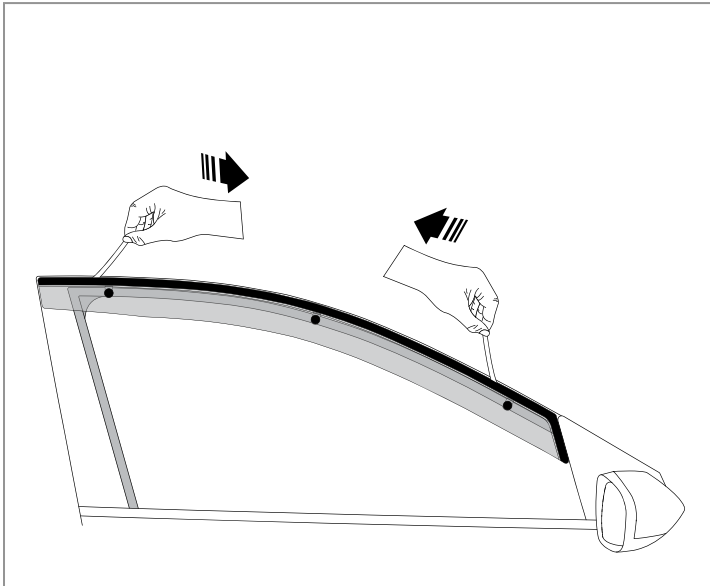

Ruler 6

- NOTE**
- A. Fully remove and discard the tape liner by pulling from both ends.

 Be careful not to tear the tape liner as it is removed.

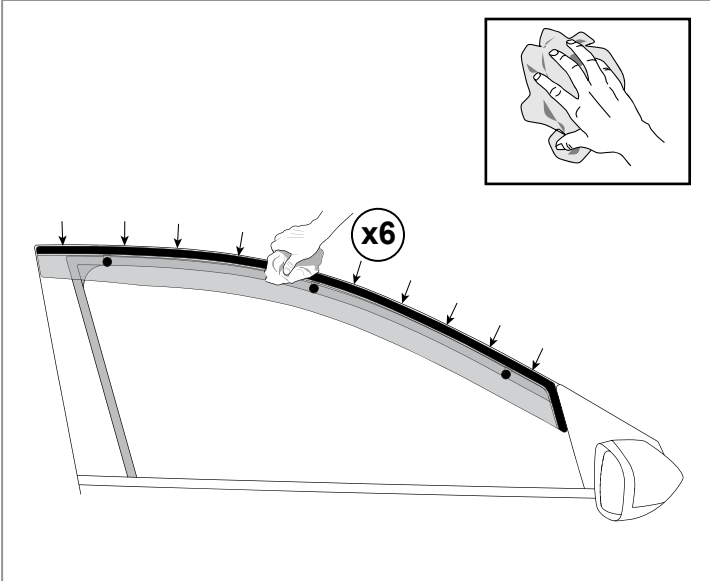

Lint Free Cloth 7

- NOTE**
- A. Using a Lint Free Cloth, apply firm downward pressure to the entire tape flange six (6) times to promote maximum adhesion of the Door Visor to the door frame.
 - B. Repeat steps 1-7 for Front Left Hand Side.
 - C. Remove "L" and "R" labels from both front Door Visors.

 It is critical that the part is correctly pressed down and the clips are properly fitted to ensure the function of the part.

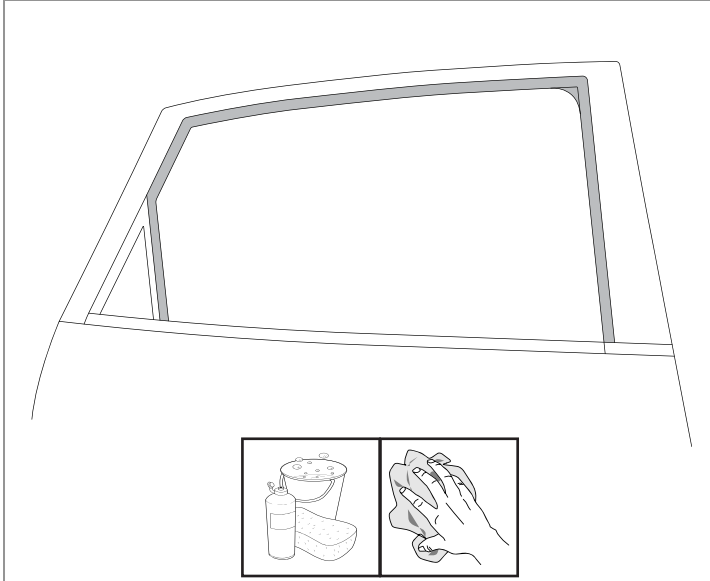

Soap and Water and Lint Free Cloth 8

- NOTE**
- A. Using Soap and Water, thoroughly clean the Rear RH upper door frame and surrounding areas.
 - B. Wipe away any residue with a Lint Free Cloth as shown.
 - C. Lower the window.

 Make sure all surfaces are completely dry before trial fitting the Door Visor.

Genuine Accessories

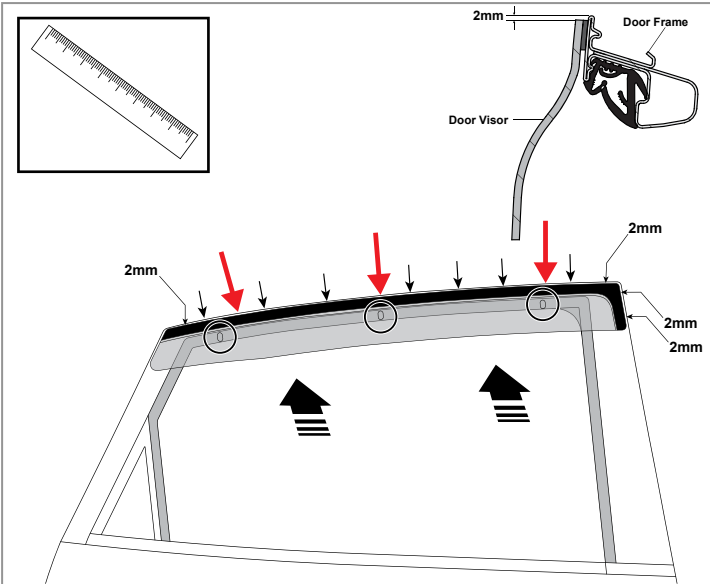

Non-Permanent Marker or Pencil and Ruler 9

- NOTE**
- A. Remove the protective film from the Door Visor.
 - B. Trial fit the Rear RH Door Visor onto the door frame. Using a Ruler, align the top edge of the Door Visor 2mm below the top of the door edge, while locating the front edge of the Door Visor 2mm back from the door edge.
 - C. Using a Non-Permanent Marker or Pencil, mark the location of the three (3) holes in the Door Visor and where they correspond to the door frame, as shown.
- Make sure all surfaces are completely dry before proceeding to the next step.

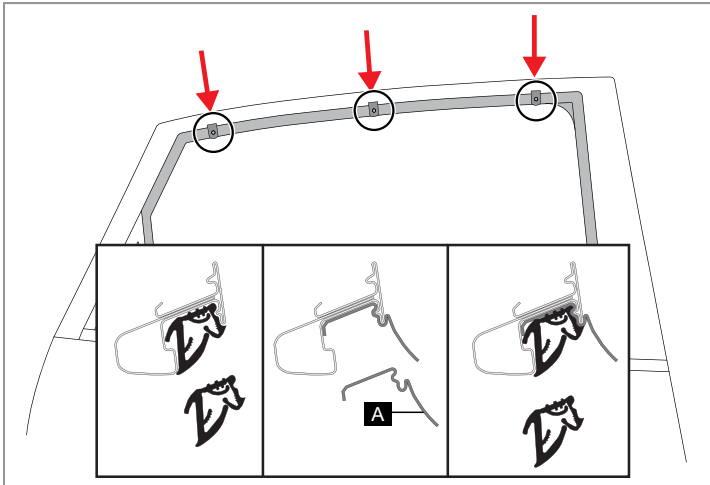

10

- NOTE**
- A. From the center of the upper door frame, separate the rubber window seal from the door frame. Do not remove the rubber window seal from the front or rear corners of the upper door frame.
 - B. Install one (1) metal clip "A" between the door frame and rubber window seal at the Front Marked Position.
 - C. Install one (1) metal clip "A" between the door frame and rubber window seal at the Rear Marked Position.
 - D. Install one (1) metal clip "A" between the door frame and rubber window seal at the Center Marked Position.
 - E. Reinstall the rubber window seal into the door frame. Ensure that the rubber window seal is correctly seated.
- Ensure the rubber window seal is correctly seated. Be careful not to damage the rubber window seal.

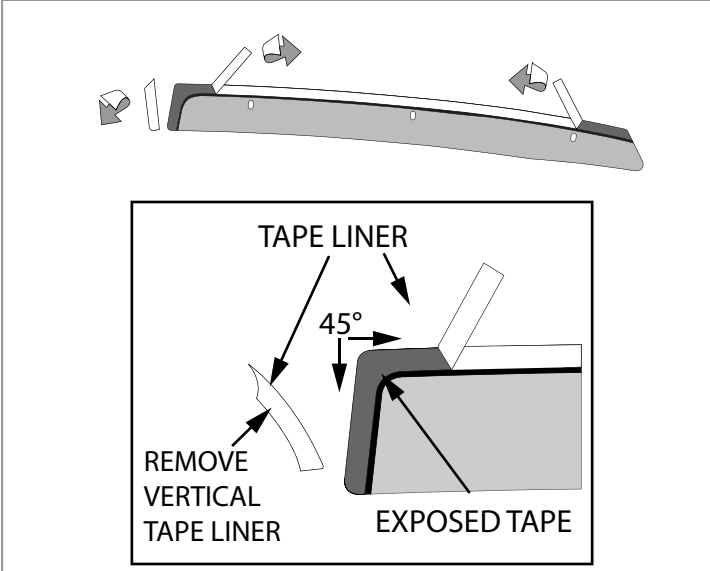

50/50 Isopropyl Alcohol (70%) & Water and Lint Free Cloth 11

- NOTE**
- A. Using 50/50 Isopropyl Alcohol (70%) & Water and a lint free cloth, thoroughly clean the entire tape attachment area.
 - Make sure to remove any marks from the Non-Permanent Marker or Pencil.
 - B. Peel back approximately 50mm (2") of the tape liner at each end and fold at 45° to the outside of the Door Visor as shown.
 - C. Fully remove the small vertical tape liner.
- Do not touch the exposed tape with hands, allow to get dirty or leave exposed for an extended period of time.

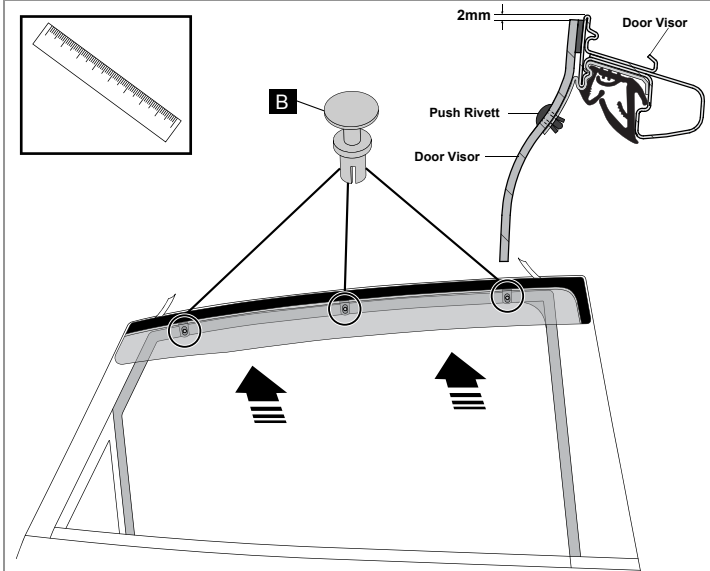

Ruler 12

- NOTE**
- A. Using a Ruler, align the top edge of the Door Visor 2mm below the top of the door edge while locating the front edge of the Door Visor 2mm back from the door edge.
 - B. Ensure the tape liners from step 11 are exposed.
 - C. Install three (3) push rivets "B" through the Door Visor into the three (3) metal clips, by pressing down on the center of the push rivet "B".
- Apply only light pressure to the front and rear corners of the Door Visor during the installation of the push rivets.

Genuine Accessories

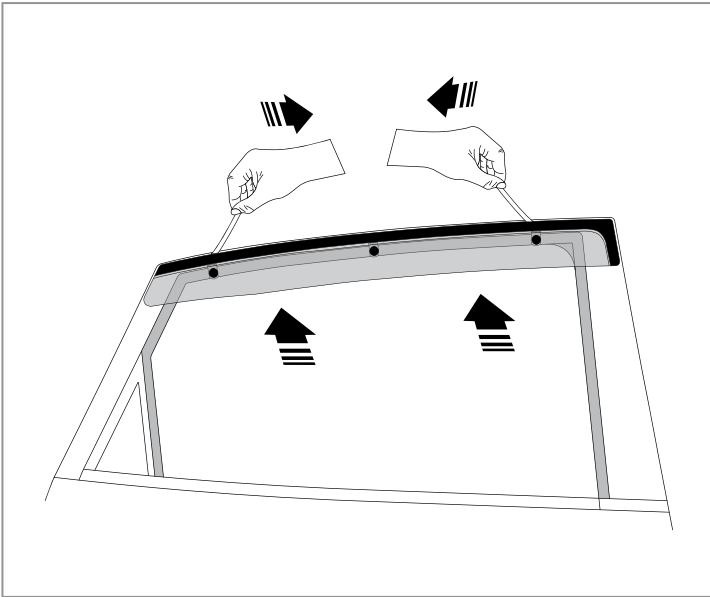

13

NOTE
A. Fully remove and discard the tape liner by pulling from both ends.

 Be careful not to tear the tape liner as it is removed.

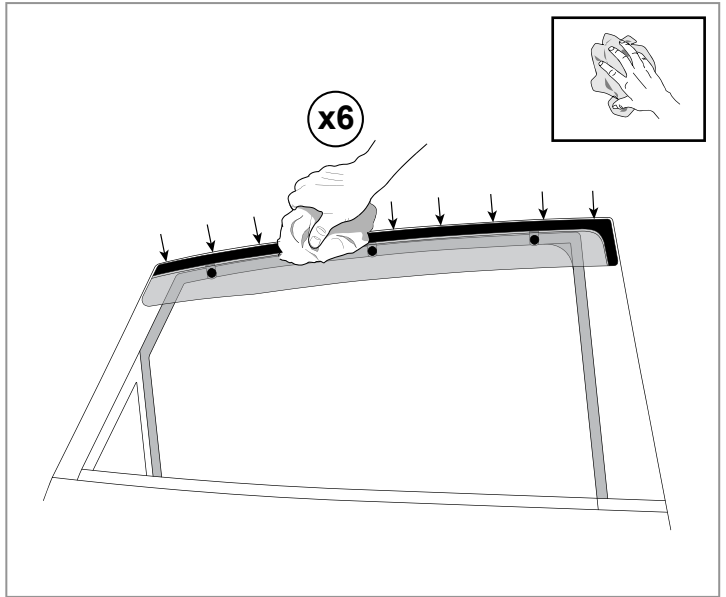



Lint Free Cloth 14

NOTE
A. Using a Lint Free Cloth, apply firm downward pressure to the entire tape flange six (6) times to promote maximum adhesion of the Door Visor to the door frame.
B. Repeat steps 8-14 for Rear Left Hand Side.
C. Remove "L" and "R" labels from both Rear Door Visors.

 It is critical that the part is correctly pressed down to ensure the function of the part.

Genuine Accessories

Visual Check

Items To Be Checked	Results of the Check
 Check position of the Door Visor to make sure that it is positioned correctly. (Step 5 & 12)	Correct fitment.
 Remove all “L” and “R” labels from Door Visors. (step 7 & 14)	“L” and “R” labels are removed.
 Conduct final inspection, ensuring all clips and push rivets are correctly installed and fully engaged. Close doors and check clearances at all edges for interference.	Final Inspection.

Genuine Accessories

Care & Cleaning

Put this page in the customer's glovebox, for future reference.

Cleaning Instructions for:

J9F22 AU000

Spray with a firm water spray to remove any loose dirt, then wash with water, detergent and a soft cloth or sponge.
DO NOT use petroleum based solvents or abrasives.

Retain these instructions in your glovebox for future reference.