

Genuine Accessories



Vehicle Model Kona

Model Year 2018~
 Part No. J9F62 AU000 (DIO)
 J9F62 AU600 (PIO)
 Language English
 Rev. Date 3/9/2020

Accessory: Mirror, Auto-dim with HL5 & Comp.









Difficulty: (B)

Note: Difficulty stated above reflects the minimum level of expertise required to install the accessory:
 (A) Customer
 (B) Dealer Technician
 (C) Master Technician or Specialist









Application Notes

For vehicles equipped with Auto-Dimming Mirror (without HomeLink or Compass) only follow steps 1, 11~14, 19, 20, 34~37, 39~42.

Instructional Symbols / Definitions

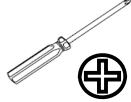
 Denotes warnings that may lead to serious physical injury or vehicle damage  Denotes cautions to be taken to avoid physical injury or electronic component damage  Denotes cautions to be taken to avoid vehicle and component damage	 Denotes quality processes to be checked prior to moving to the next step  Denotes specific tools that are necessary to complete a step <div style="border: 1px solid black; padding: 2px; text-align: center; width: 20px; margin: 0 auto;">N O T E</div> Denotes important information to be reviewed during the step	Denotes personal protective equipment (PPEs) that may be required for a step. Examples of safety equipment icons noted below: <div style="display: flex; justify-content: space-around;"> <div style="text-align: center;">  Glasses </div> <div style="text-align: center;">  Gloves </div> </div> <div style="display: flex; justify-content: space-around; margin-top: 10px;"> <div style="text-align: center;">  Mask </div> <div style="text-align: center;">  Hearing Protection </div> </div>
---	---	---

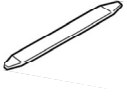
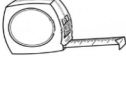
Basic Required Tools

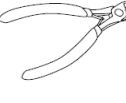
 Ratchet	 Extension	 M10 10mm Socket	 T20 T20 Torx Socket	 Torque Wrench	 #2 Phillips Screwdriver
 T20 T20 Torx Driver	 Nylon Panel Removal Tool	 Tape Measure	 Pliers	 Side Cutters	

Notes to the installer:

- 1) Read the entire Installation Instructions prior to beginning the installation of the part.
- 2) If applicable, scan the barcode label located on the accessory part or packaging prior to installing, to register the part. If this accessory is installed as a replacement, register the removal of the old part before registering the new part. Old and new parts will have different barcode data, and the old registration cannot be reused.
- 3) Make sure the vehicle is completely clean and dry in the area(s) the part is to be installed.
- 4) Ensure the vehicle is properly protected in the area(s) that the accessory is to be installed.
- 5) NEVER place tools on painted surfaces, seating surfaces, dash pad, console or floor carpet/mats.
- 6) Always wear appropriate personal protective equipment, including gloves, safety glasses, etc., when required.
- 7) Record radio presets prior to disconnecting battery power, if needed.
- 8) Ensure the transportation fuse is set to "ON" before starting the install.
- 9) Roll down the driver's window and adjust the power seats (if applicable) prior to disconnecting battery power, if needed.
- 10) Factory wire harness colors are subject to change, please use the specified pin # in the connector to identify the correct wire for T-Tap installation.
- 11) Discard the provided wire cover, item 8 on page 2, if the vehicle has the plastic shroud attached to the windshield as noted in step 10 on page 6.

Genuine Accessories

Kit Overview

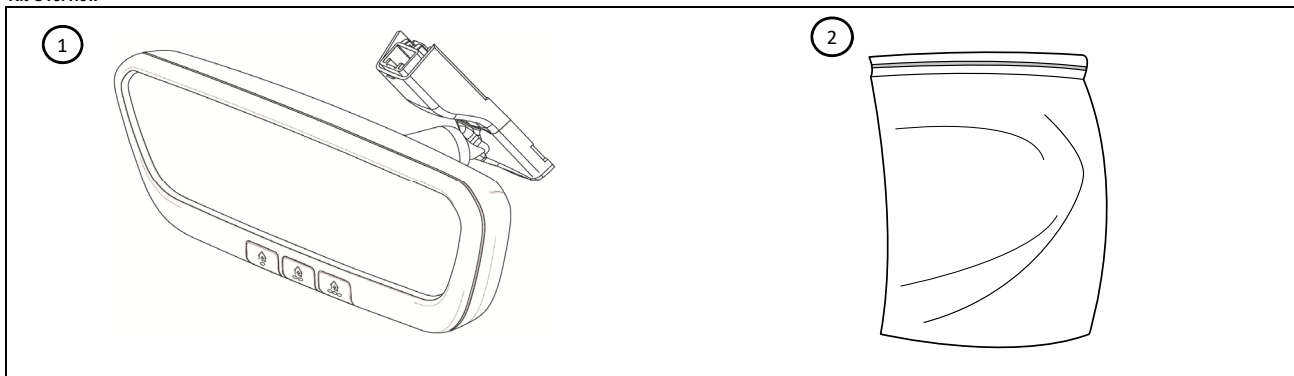

No.	Qty	Description
1	1	Mirror, Auto-dimming w/ HL5 & Compass
2	1	Hardware Kit

Hardware Kit Contents

A	
1	Harness

B	
1	Wire Cover

C	
1	A-Pillar Tether Clip 85815 C1100

D	
8	Foam Tape*

E	
2	T-Tap*

F	
10	Wire Tie*

G	
1	Quick Ref. Guide

* Indicates extra components intentionally included in kit as spares.
Follow instructions for proper placement of each component.



Hardware Total
24

Radio Presets - record customer preset frequencies if disconnecting battery power



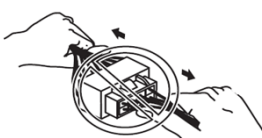
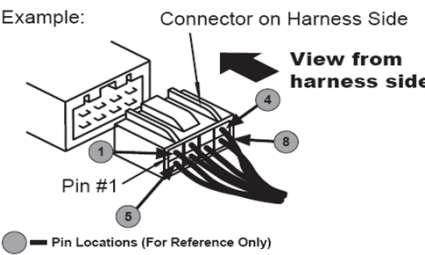
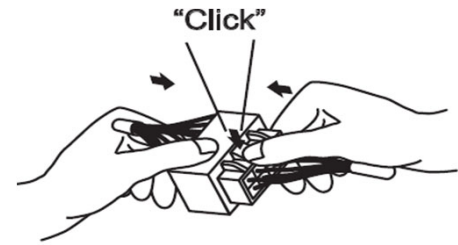
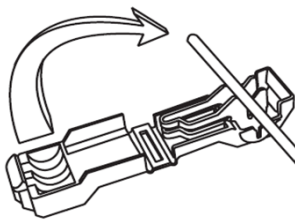
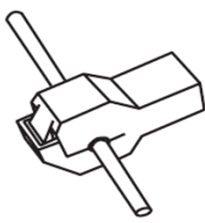
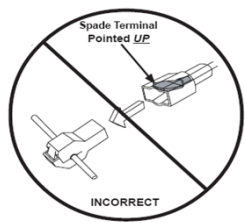
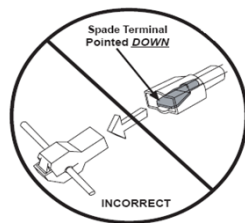
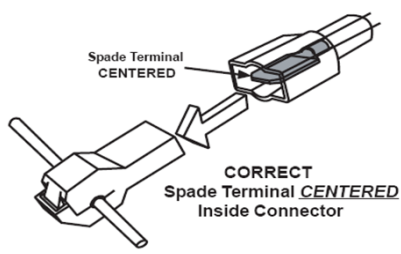

FM1 _____	FM2 _____	FM3 _____	FM4 _____	FM5 _____
FM6 _____	FM7 _____	FM8 _____	FM9 _____	FM10 _____
AM1 _____	AM2 _____	AM3 _____	AM4 _____	AM5 _____
SAT1 _____	SAT2 _____	SAT3 _____	SAT4 _____	SAT5 _____

Genuine Accessories

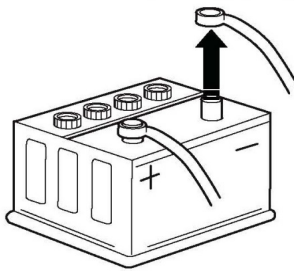

Electrical Connection Procedure

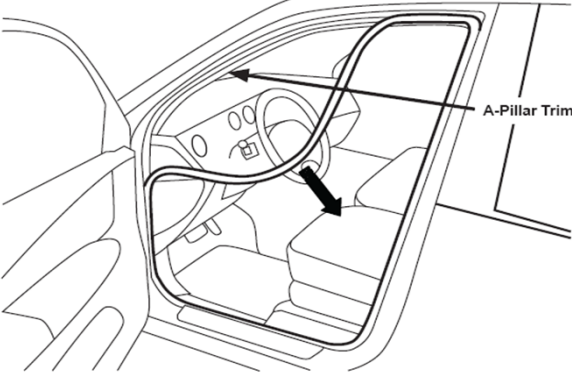

<p style="text-align: center;">Wire Appearance</p> <p>Wires may be solid color, or striped (tracer). The first color in the description indicates the base color of the wire; the second indicates the stripe.</p> <p>Example:</p> <div style="display: flex; justify-content: space-around;"> <div style="text-align: center;"> <p>Solid color wire</p>  <p>Black</p> </div> <div style="text-align: center;"> <p>Striped Wire</p>  <p>White (Base Color)</p> <p>Red (Stripe Color)</p> </div> </div>	<p style="text-align: center;">Disconnecting Connectors</p> <p>When disconnecting the wires, grasp the connectors, not the wires.</p> <p>Example:</p> <div style="display: flex; justify-content: space-around;"> <div style="text-align: center;"> <p>Correct</p>  </div> <div style="text-align: center;"> <p>Incorrect</p>  </div> </div>
<p style="text-align: center;">Connector Diagrams</p> <p>Connector diagrams show the harness side view, unless noted. The wire pin numbers are shown from the wire harness side, not the connector side.</p> <p>Example:</p> 	<p style="text-align: center;">Connecting Connectors</p> <p>When locking connectors, listen for an audible "click" indicating the connectors are securely locked.</p> <p>Example:</p> 
<p>T-Tap Install Procedure</p>	
<p>1. Place the T-Tap on the vehicle wire</p> 	<p>2. Using pliers, close and crimp T-Tap around the vehicle wire.</p> <div style="display: flex; justify-content: space-around;">  <div style="text-align: center;">  <p>INCORRECT</p> </div> <div style="text-align: center;">  <p>INCORRECT</p> </div> </div> <p style="text-align: center;">** Extreme care must be taken to ensure the male spade is inserted into the T-Tap properly</p>
<p>3. Insert accessory harness wire with male spade terminal into the opening in T-Tap.</p>  <p style="text-align: center;">CORRECT Spade Terminal <u>CENTERED</u> Inside Connector</p>	

Genuine Accessories

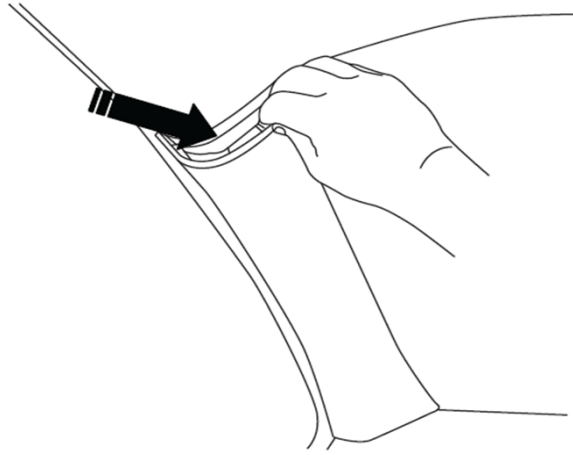

1		Ratchet and 10mm Socket
		
<div style="display: flex; justify-content: space-around; align-items: center;">   </div>		
N O T E	<p>A. Ensure the correct part is being installed. Verify the part number on the installation orders with the part number on the kit box label.</p> <p>B. Write down all pre-set radio stations (if applicable).</p> <p>C. Open the hood and remove negative battery terminal cover, if applicable, and disconnect/isolate vehicle's negative battery cable.</p>	
	<p>WARNING: Shock Hazard! Do not touch vehicle's negative battery terminal to vehicle's positive battery terminal. Serious injury and damage to the vehicle may occur.</p>	

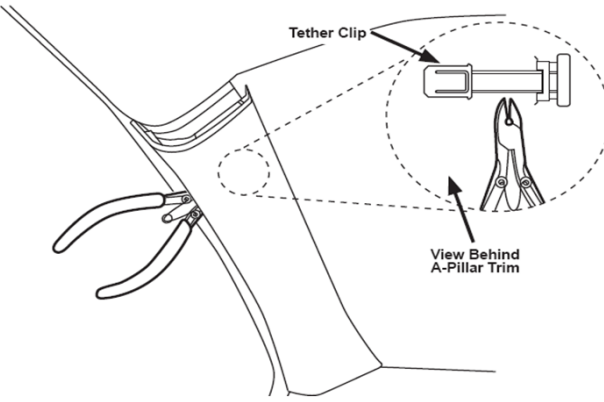
2		
		
N O T E	<p>A. Carefully pull the front of the driver-side door seal back to allow removal of the A-pillar trim panel and dash side panel.</p>	



3		Nylon Panel Removal Tool
		
N O T E	<p>A. Partially remove the A-pillar trim panel by pulling the top out towards the vehicle passenger-side, until the A-pillar tether clip catches.</p>	
	<p>CAUTION: Ensure care is taken to prevent damage to the A-pillar trim panel, wire harness, sunroof drain tube, and side-curtain airbag.</p>	

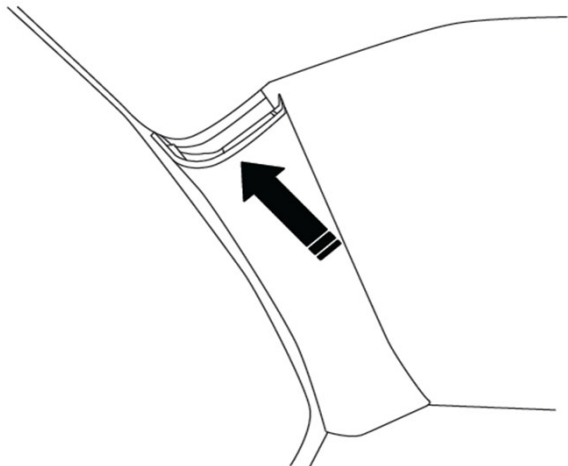

4		Side Cutters
		
N O T E	<p>A. With A-pillar trim partially pulled away, reach behind trim panel and cut tether clip, as shown above.</p>	
	<p>CAUTION: If needed, use a flashlight to light behind the A-pillar trim to avoid damaging any vehicle component with the side cutters. DO NOT cut anything other than the A-pillar tether clip.</p>	

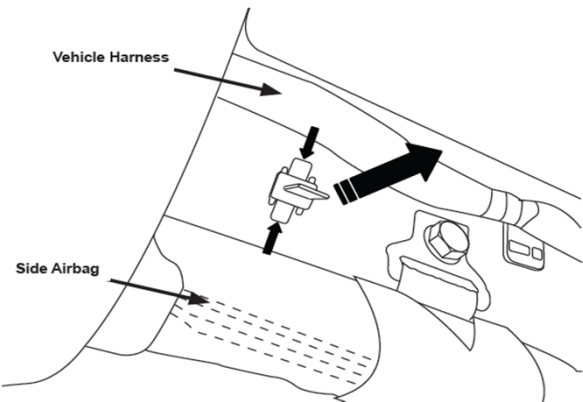
Genuine Accessories

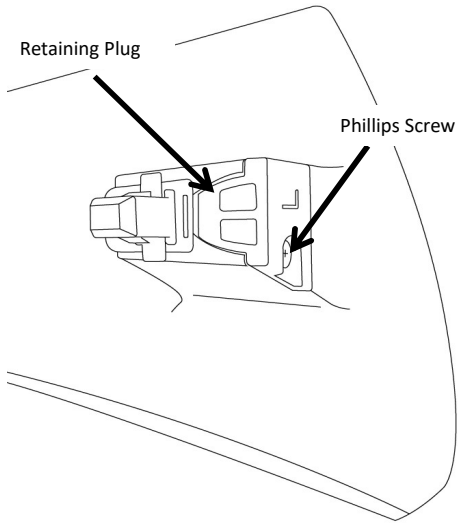
5		
		
N O T E	<p>A. Continue removing the A-pillar trim panel by pulling the top out toward the passenger side of the vehicle, until remaining one (1) clip is released and set aside.</p>	
	<p>CAUTION: Do not damage A-pillar trim panel or headliner.</p>	

6		Pliers
		
N O T E	<p>A. Using pliers, pull the remaining portion of the A-pillar tether clip out of the A-pillar, and discard.</p>	

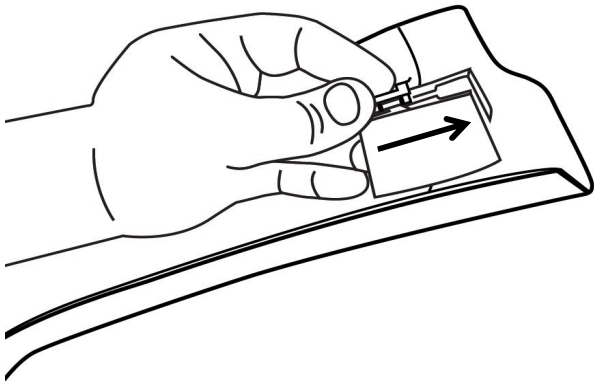
7		#2 Phillips Screwdriver
		
N O T E	<p>A. Remove one (1) Phillips screw (shown) from inside of A-pillar trim. B. Remove retaining plug.</p>	
	<p>CAUTION: Do no scratch or damage the A-pillar trim panel.</p>	

8		
		
N O T E	<p>A. Grasp the clip, and slide toward the bottom of the A-pillar trim, then pull the remaining clip piece out of the trim panel. B. Discard the clip.</p>	
	<p>CAUTION: Do no scratch or damage the A-pillar trim panel.</p>	

Genuine Accessories



9		#2 Phillips Screwdriver
N O T E	<p>A. Place a new tether clip in the A-pillar trim panel by aligning the slot on the trim panel with the tether clip.</p> <p>B. Slide the clip upward until it locks in place.</p> <p>C. Re-install the retaining plug and screw, removed in the previous step.</p>	
	<p>WARNING: ALWAYS use a new tether clip when re-installing the A-pillar trim panel. Failure to use a new clip may result in serious injury or death in the event the airbag deploys. Do not damage the A-pillar trim panel or tether clip.</p>	



10		
N O T E	<p>A. Determine if vehicle is equipped with plastic shroud attached to the windshield, behind the mirror. If no plastic shroud is installed, skip ahead to step 14. If a plastic shroud is installed, continue to step 11.</p>	

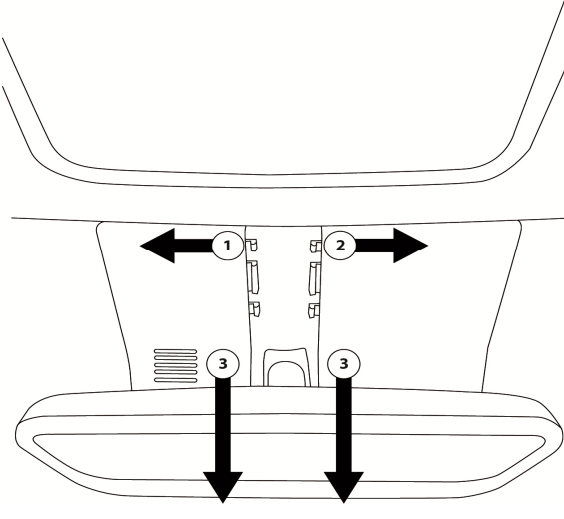

11		
N O T E	<p>A. Gently tilt the mirror head downward to expose upper portion of plastic shroud.</p>	

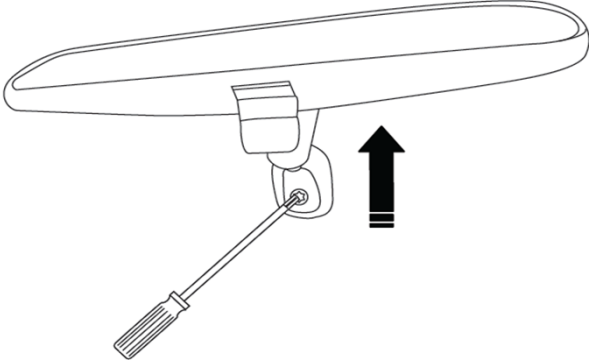

12		
N O T E	<p>A. Remove center cover of plastic shroud by inserting your finger into the upper radius of the hole and gently pulling the center cover away from the windshield and set aside.</p>	
	<p>CAUTION: Do not damage plastic shroud, center cover, or headliner.</p>	

Genuine Accessories

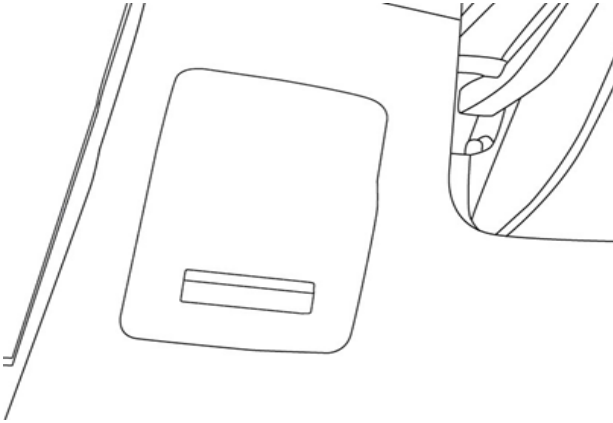
13		Nylon Panel Removal Tool
		
N O T E	<p>A. Remove the remaining portion of plastic shroud by gently pressing the shroud to the left from location 1 until it disengages.</p> <p>B. Repeat on the right side by pressing from location 2 until it disengages.</p> <p>C. Slide the shroud down the windshield from location 3 and set aside.</p>	
	<p>CAUTION: Do not scratch or damage plastic shroud. Do not break the retaining tabs on the plastic shroud.</p>	

14		T20 Torx Driver
		
N O T E	<p>A. Using a T20 Torx Driver, loosen the screw on the mirror mount.</p> <p>B. Gently pull the mirror upwards in a parallel direction to the windshield. DO NOT pull the mirror away from the windshield.</p> <p>C. If vehicle is equipped with an Auto-Dimming mirror (without HomeLink or Compass), unplug the 10-pin connector.</p>	
	<p>CAUTION: Take care to avoid damaging the mirror mount, windshield, headliner and connector.</p>	

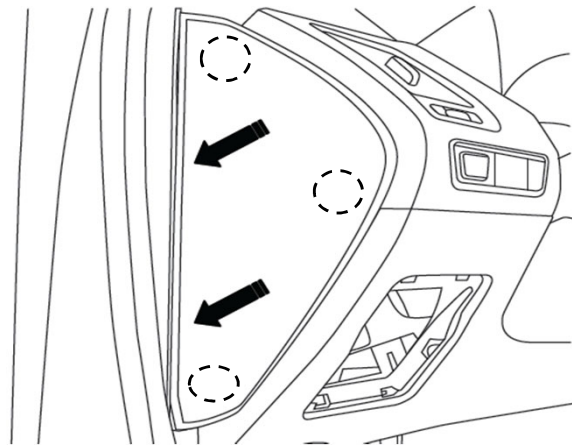

15		
		
N O T E	<p>A. Remove the fuse panel cover, and set aside.</p>	
	<p>CAUTION: Do NOT scratch the Fuse Panel Cover.</p>	

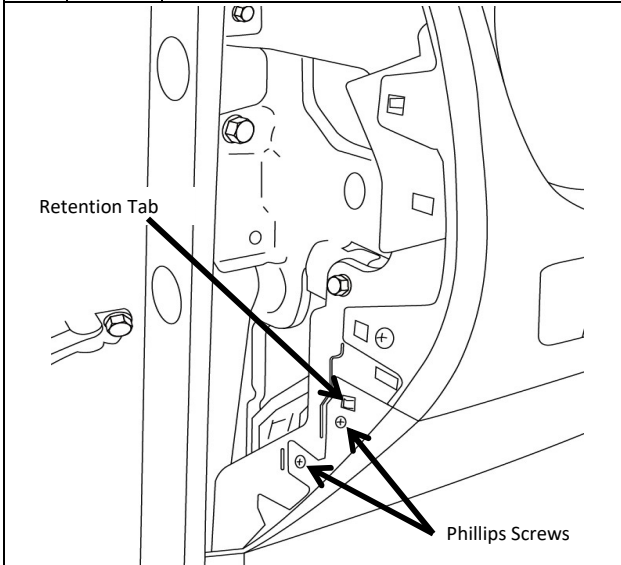

16		Nylon Panel Removal Tool
		
N O T E	<p>A. Reach through the fuse panel opening and push the Dash Side Panel out, by dislodging the three (3) clips.</p> <p>B. Remove the Dash Side Panel and set aside.</p>	
	<p>CAUTION: Do NOT scratch the Dash Side Panel.</p>	

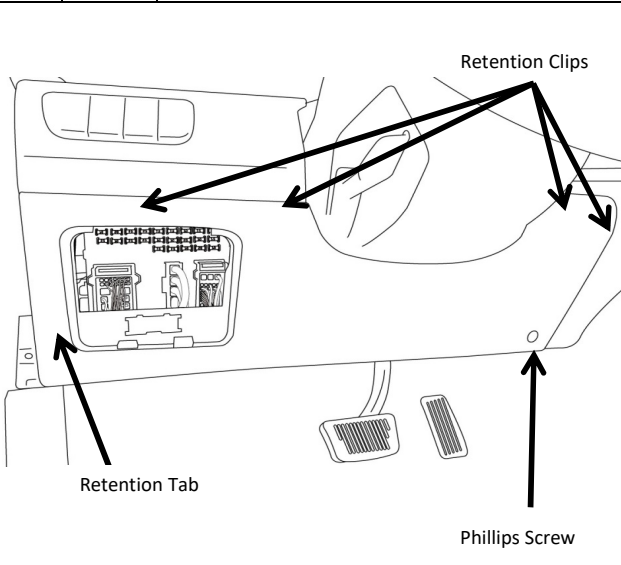
Genuine Accessories

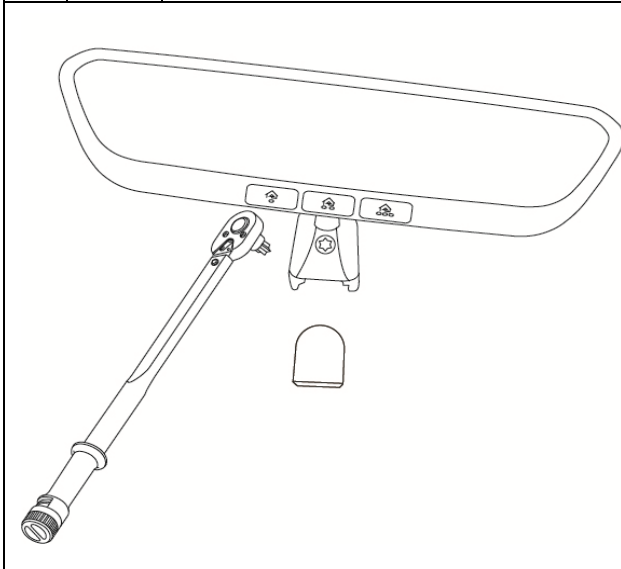

17		#2 Phillips Screwdriver
		
N O T E	<p>A. Remove two (2) Phillips screws as shown. B. Disengage retention tab.</p>	

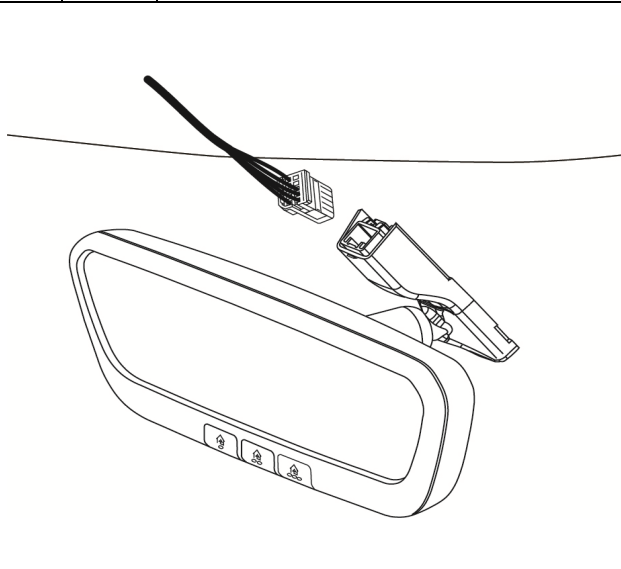

18		Nylon Panel Removal Tool and #2 Phillips Screwdriver
		
N O T E	<p>A. Remove one (1) Phillips screw. B. Disconnect the OBDII connector from the lower dash panel. C. Disengage retention clips shown above, remove the lower dash panel and set aside in a safe place.</p>	

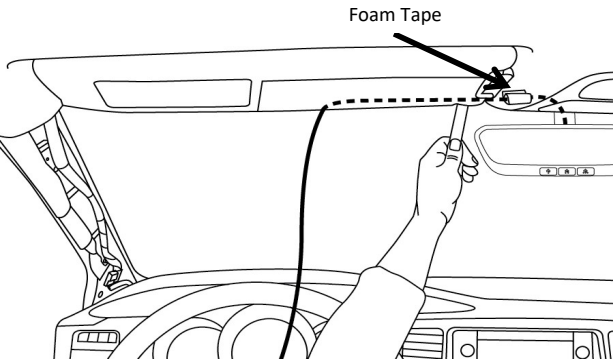

19		T20 Torx Bit, Ratchet, and Torque Wrench
		
N O T E	<p>A. Slide the new mirror over the windshield button. B. Using a torque wrench and T20 Torx Bit, torque the T20 Torx screw to: 1.76 N-m (0.18 kgf-m, 15.6 lb-in).</p>	
	<p>WARNING: Do not over-tighten the screw. Over tightening the screw will not properly secure the mirror, and could cause the mirror to break loose and injure the occupants in an accident.</p>	

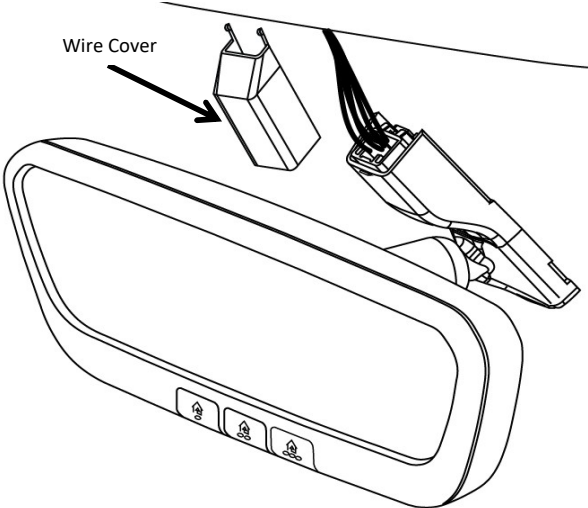

20		
		
N O T E	<p>A. Plug the 10-pin connector of the provided mirror harness into the mirror and ensure it is locked in place by gently pulling on harness to make sure it is locked.</p>	
	<p>CAUTION: Ensure 10-pin connector is securely installed.</p>	

Genuine Accessories

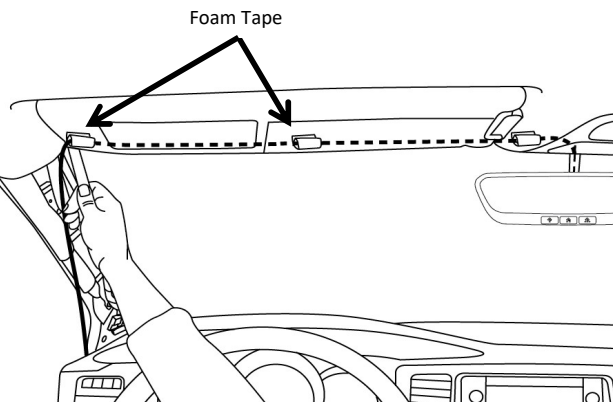
21		Nylon Panel Removal Tool
		
NOTE	<ol style="list-style-type: none"> 1. Wrap one (1) foam tape around the mirror harness in the location shown. 2. Begin tucking the mirror harness between the headliner and the roof. Stop after the first foam-tape harness is hidden under the headliner. 	
	CAUTION: Use caution when working with the headliner to prevent creases or damage. Make sure hands are clean.	

22		
		
NOTE	<ol style="list-style-type: none"> 1. For vehicles not equipped with plastic shroud, slide the provided wire cover over the mirror harness lead, and click it into the top surface of the mirror base. 2. Extend the upper wire cover until it hooks onto the headliner. Ensure the cover is vertical. 	
	CAUTION: Ensure cover "forks" are properly seated into headliner.	

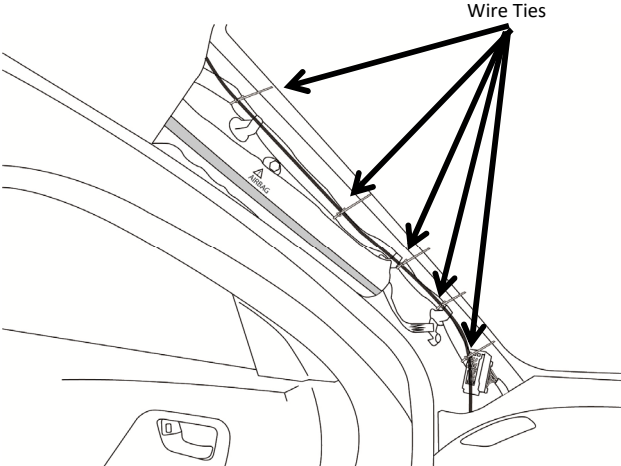
23		Nylon Panel Removal Tool
		
NOTE	<ol style="list-style-type: none"> A. Hold the mirror harness against the headliner and wrap one (1) foam tape around the harness where it meets the corner of the A-pillar. B. Wrap one (1) foam tape on the harness between the two previously installed foam tapes. C. Tuck the harness with the wrapped foam tape into the headliner across from the mirror to the A-pillar. 	
	CAUTION: Use caution when working with the headliner to prevent creases or damage. Make sure hands are clean.	

24		Side Cutters
		
NOTE	<ol style="list-style-type: none"> A. Route mirror harness down the A-pillar into the dash, toward side of fuse panel. NOTE: Ensure wire harness is routed away from the side curtain airbag and sunroof drain tube, if equipped. B. Secure mirror harness near the vehicle harness clips and above the electrical connector at the bottom of the A-pillar, with five (5) wire ties. C. Trim the excess wire tie material. 	
	CAUTION: DO NOT secure to airbag inflator. DO NOT secure to sunroof drain tube, if equipped.	

Genuine Accessories

25 

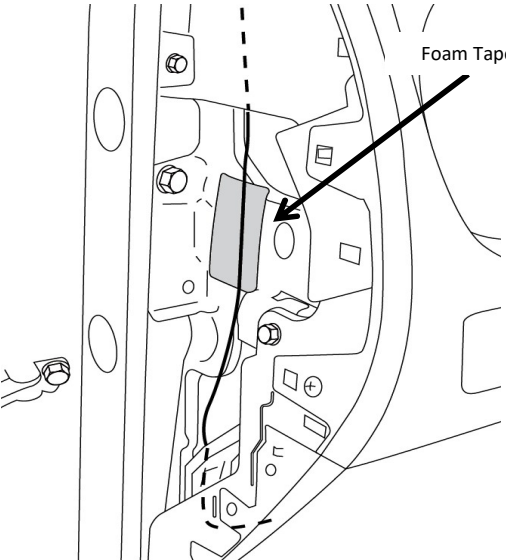

Foam Tape

NOTE

A. Route mirror harness towards side dash, over metal support structure, as shown.
 B. Place one (1) foam tape over metal structure as shown.
 C. Continue routing harness towards fuse box as shown.

 **CAUTION:** Ensure harness does not catch on vehicle component, or is damaged during the routing.

26 

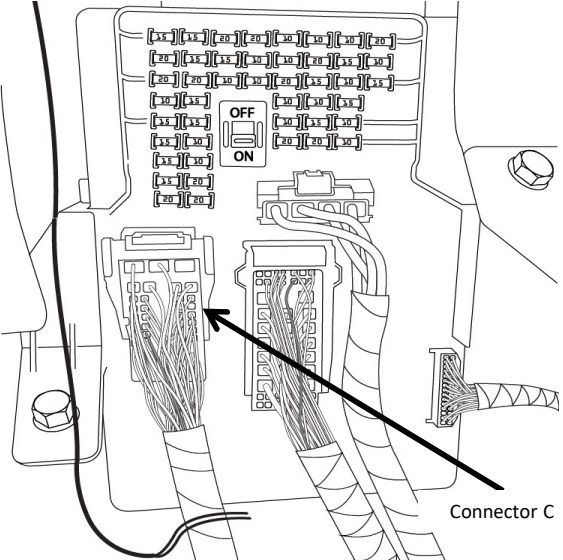

Connector C

NOTE

A. Locate Connector C (38-Pin connector) on the front side of the fuse box (furthest side from the engine).

27  Tape Measure

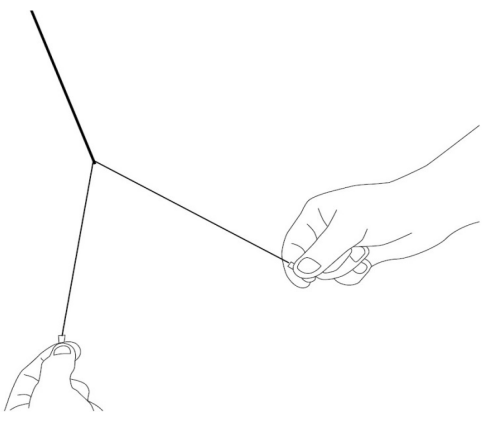

NOTE

A. Pull mirror harness wires apart approximately 275mm (11in), as shown.

 **CAUTION:** DO NOT use a razor blade or any other sharp tool to separate the wires. Ensure wire is not damaged during separation.

28 

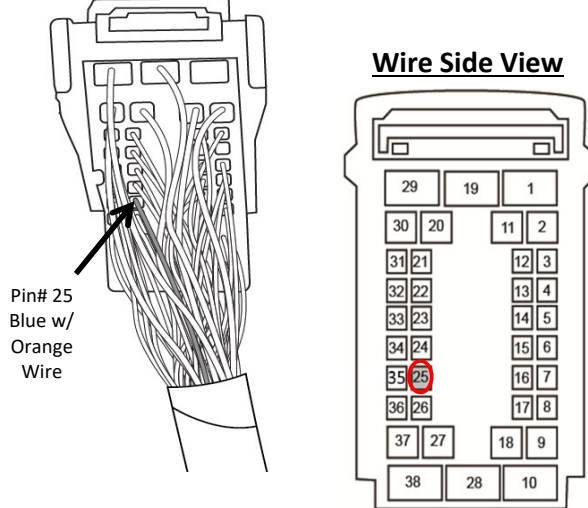

Pin# 25
Blue w/
Orange
Wire

Wire Side View

29	19	1
30	20	11
31	21	12
32	22	13
33	23	14
34	24	15
35	25	16
36	26	17
37	27	18
38	28	10



NOTE

A. Locate Pin# 25 (Blue w/ Orange wire) of Connector C, as shown.

 **CAUTION:** Ensure the correct wire is identified. NOTE: Factory wire colors are subject to change at any time. Refer to the pin number location above to correctly identify the circuit.

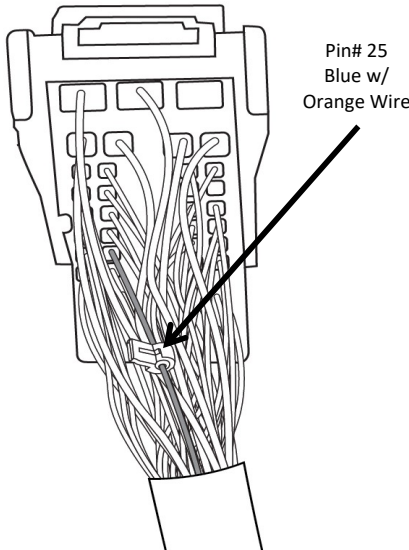
Genuine Accessories

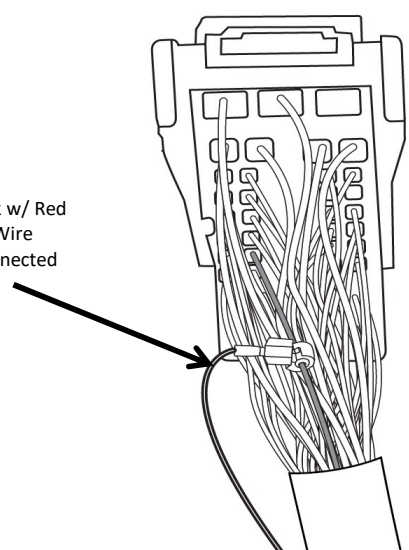
29		Pliers
		
N O T E	<p>A. Peel back insulation tape approximately 1.5" from the end of the connector to make room for the T-Tap if necessary.</p> <p>B. Attach one (1) T-Tap to the wire at Pin 25 (Blue w/ Orange wire), as shown. Use Pliers to snap the T-Tap together. Refer to the Electrical Connection Procedure at the beginning of the instructions for more details.</p>	

30		
		
N O T E	<p>A. Insert male spade terminal of the mirror harness (Black w/ Red wire) into the T-Tap connector (Blue w/ Orange wire), for switched ignition power. Refer to the Electrical Connection Procedure at the beginning of the instructions for more details.</p>	
 <p>CAUTION: Ensure the male spade connector is fully inserted into the wire tap. Check that the spade did not "miss" the female slot. Check that the male spade is not visible on either side of the female connector.</p>		

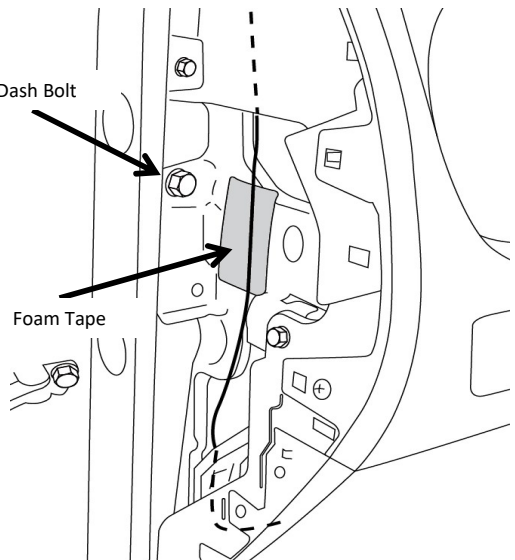
31		10mm Socket, Extension, and Ratchet
		
N O T E	<p>A. Locate the 10mm dash bolt, on the dash just above the drivers side door hinge.</p> <p>B. Remove the 10mm dash bolt.</p>	

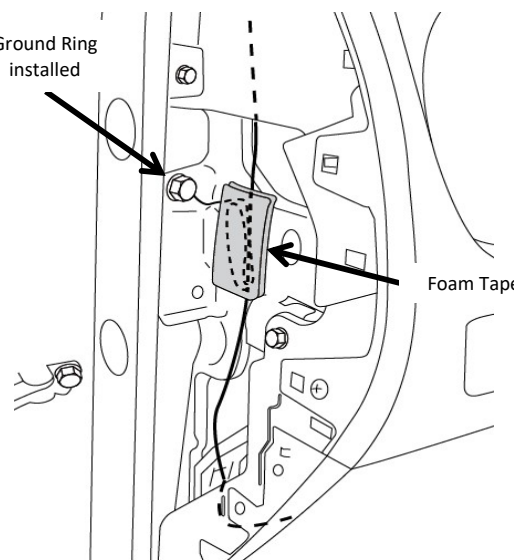
32		10mm Socket, Extension, Ratchet, and Torque Wrench
		
N O T E	<p>A. Route ground wire with ring up to dash bolt hole.</p> <p>B. Place the ground wire ring of the mirror harness onto the dash bolt.</p> <p>C. Secure the dash bolt, and torque to: 8.8 ~ 12.7 N.m (0.9 ~ 1.3 kgf.m, 6.5 ~ 9.4 lb-ft).</p> <p>D. Place one (1) additional foam tape as shown to secure harness.</p>	

Genuine Accessories

33		Side Cutters
N O T E	<p>A. Use two (2) wire ties to secure excess mirror harness to the factory harness as shown.</p> <p>B. Use side cutters to trim loose ends from wire ties.</p> <p>C. Place one (1) piece of foam tape to secure the harness to side of fuse box, as shown.</p>	



34		10mm Socket, Ratchet, and Torque Wrench
N O T E	<p>Function Check Preparation:</p> <p>A. Reconnect the negative battery cable, and torque to: 5.0 ~ 6.0 N.m (0.50 ~ 0.60 kgf.m, 45 ~ 52 lb-in).</p> <p>B. Reinstall the battery terminal cover, if applicable, and close hood.</p>	
<p>WARNING: Shock Hazard! Do not touch vehicle's negative battery terminal to vehicle's positive battery terminal. Serious injury and damage to the vehicle may occur.</p>		

35		Function Check
N O T E	<p>A. Cover the forward-facing photocell with a dark cloth or towel.</p> <p>B. Turn the ignition to "ON".</p> <p>C. With the dark cloth in place, and the power on, the mirror will darken.</p> <p>D. Remove the dark cloth, and the mirror will return to normal.</p>	

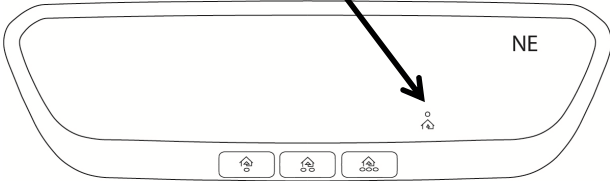

36		Function Check
N O T E	<p>A. Verify that a direction or calibrate (such as "NE" or "C") is displayed in the display window.</p>	

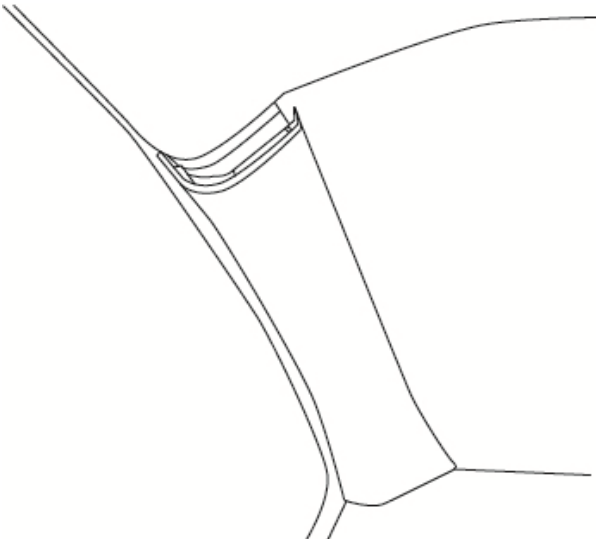
Genuine Accessories

37		Function Check
		
N O T E	<p>A. Ensure that the ignition is still "ON"</p> <p>B. Press each HomeLink button, one-at-a-time, and verify that the LED indicator illuminates from behind the glass. Press the HomeLink button a second time to turn off the feature.</p> <p>C. Turn off ignition.</p>	

38		
		
N O T E	<p>A. Ensure a new tether clip has been inserted into the A-pillar trim panel and begin re-install of the A-pillar trim panel.</p> <p>B. Insert the A-pillar lower surface into the mating surface on the top of the dash panel.</p> <p>C. Move the panel closer to the A-pillar, aligning the clips with their corresponding holes. Carefully snap the panel into place.</p>	
<p> WARNING: Always use a new tether clip when re-installing the A-pillar trim panel. Failure to use a new clip may result in serious injury or death in the event the airbag deploys.</p>		

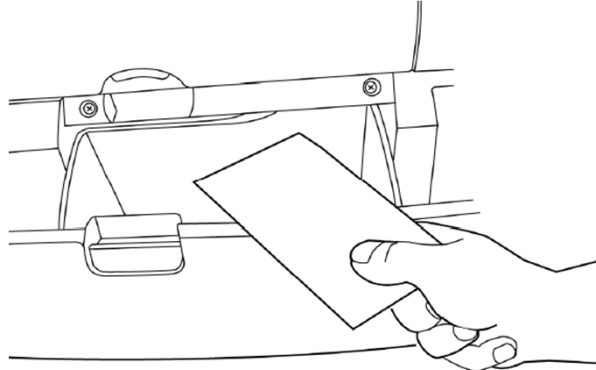
39		
Reassemble Vehicle		
N O T E	<p>A. Re-install, in reverse order, all remaining trim panels removed during installation.</p> <p>As applicable:</p> <p>A. Reinstall the plastic shroud by sliding up under mirror, engaging both top and bottom retaining tabs on one side, and then gently snapping the lower and upper tabs of the cover on the other side.</p> <p>B. Reinstall the Center Cover.</p> <p>C. Make sure there are no gaps between shroud and windshield.</p>	

40		
		
N O T E	<p>A. Place the provided one (1) Quick Reference Guide in the glove box.</p> <p>B. Clean fingerprints, smudges, etc. from mirror and windshield.</p>	
<p> CAUTION: DO NOT spray glass cleaner or other cleaning liquid directly on the mirror as it may damage the electronics.</p>		

Genuine Accessories

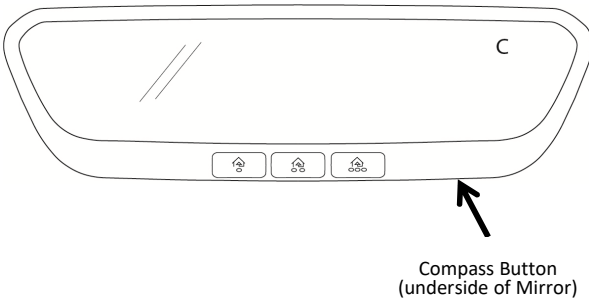
41		Dealer Only
<p>To calibrate the compass:</p> <div style="text-align: center; margin: 10px 0;">  </div>		
NOTE	<p>A. If the compass displays "C", it will need to be calibrated. B. To calibrate, drive the vehicle in up to three (3) complete circles, at less than 5mph.</p>	

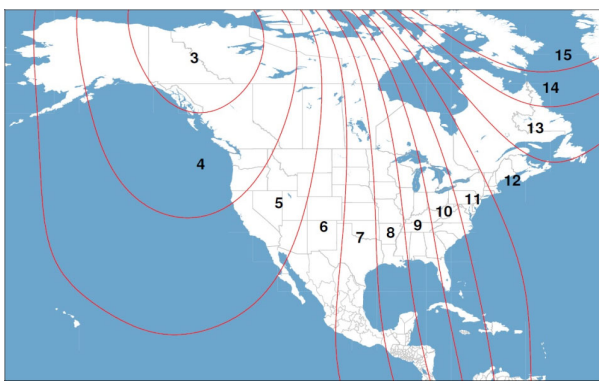
42		Dealer Only
COMPASS CALIBRATION		
		
NOTE	<p>A. Identify your approximate compass region on the above map. B. Using a paper clip, press and hold the compass button for more than 6 seconds and the current compass region code will display. C. Press the compass button until your desired compass region is displayed. Release the button and the correct compass direction will appear.</p>	







Visual Check

	Item to be Checked
	Negative battery terminal re-tightened and terminal cover is reinstalled, if applicable.
	Mirror Torx screw replaced and re-tightened.
	Harness.
	A-pillar trim panel.
	Door seal.
	Side dash trim panel.
	Fuse panel access cover.
	Dash bolt.
	Lower dash panel and OBDII connector.

	Result
	Battery cable is correctly fastened to the negative terminal. Nut is properly torqued. Cover is reinstalled if applicable
	Screw is tightened and properly torqued.
	Mirror harness connector is properly connected. T-Tap spade connector is properly seated. Harness is tucked into the headliner without causing a bulge or interference.
	Panel is securely in place. Ensure A-pillar tether clip is properly installed and seated in the A-pillar correctly.
	Seal is properly replaced, and not wrinkled.
	Panel is securely in place.
	Panel is securely in place.
	Bolt is tightened and properly torqued.
	Lower dash panel properly reinstalled and OBDII connector plugged into support bracket.

Genuine Accessories

Troubleshooting

Issue / Concern		Items to be Checked
	Mirror does not power up	<p>Confirm ground circuit connector is properly attached and locked in place.</p> <ul style="list-style-type: none"> -Check that mirror harness is properly connected at mirror. -Check that GND ring terminal is seated solidly against vehicle body at dash bolt. -Check that wire is not damaged.
	↑	<p>Confirm ignition-switched power circuit is properly connected. Circuit should NOT have power with ignition in "OFF", but should have 12V power when ignition is switched to "ON".</p> <ul style="list-style-type: none"> -Check that mirror harness is properly connected at mirror. -Check that T-Tap is connected to the proper wire. -Check that T-Tap is fully crimped onto wire. -Check that male spade is correctly inserted in T-Tap. -Check that wire is not damaged.
	Homelink does not work (House indicator does not illuminate)	<ul style="list-style-type: none"> -Check that the vehicle ignition is in the ON position. -Check that T-Tap is connected to the proper wire. -Check that T-Tap is fully crimped onto wire. -Check that male spade is correctly inserted in T-Tap. -Check that GND ring terminal is seated solidly against vehicle body at dash bolt. -Check vehicle module 2 fuse.
	Homelink does not work (House indicator does not illuminate)	<ul style="list-style-type: none"> -Replace the mirror.
	Compass does not illuminate	<ul style="list-style-type: none"> -Check that the vehicle ignition is in the ON position. -Check that T-Tap is connected to the proper wire. -Check that T-Tap is fully crimped onto wire. -Check that male spade is correctly inserted in T-Tap. -Check that GND ring terminal is seated solidly against vehicle body at dash bolt. -Check vehicle module 2 fuse
	Auto-dimming function does not work properly	<ul style="list-style-type: none"> -Check that the vehicle ignition is in the ON position. -Check that T-Tap is connected to the proper wire. -Check that T-Tap is fully crimped onto wire. -Check that male spade is correctly inserted in T-Tap. -Check that GND ring terminal is seated solidly against vehicle body at dash bolt. -Check vehicle module 2 fuse.
	Auto-dimming function does not work properly	<ul style="list-style-type: none"> -Replace the mirror.

Genuine Accessories

Wiring Diagram

Smart Junction Box Connector C IGPM_FLRS_C (Wire side View)

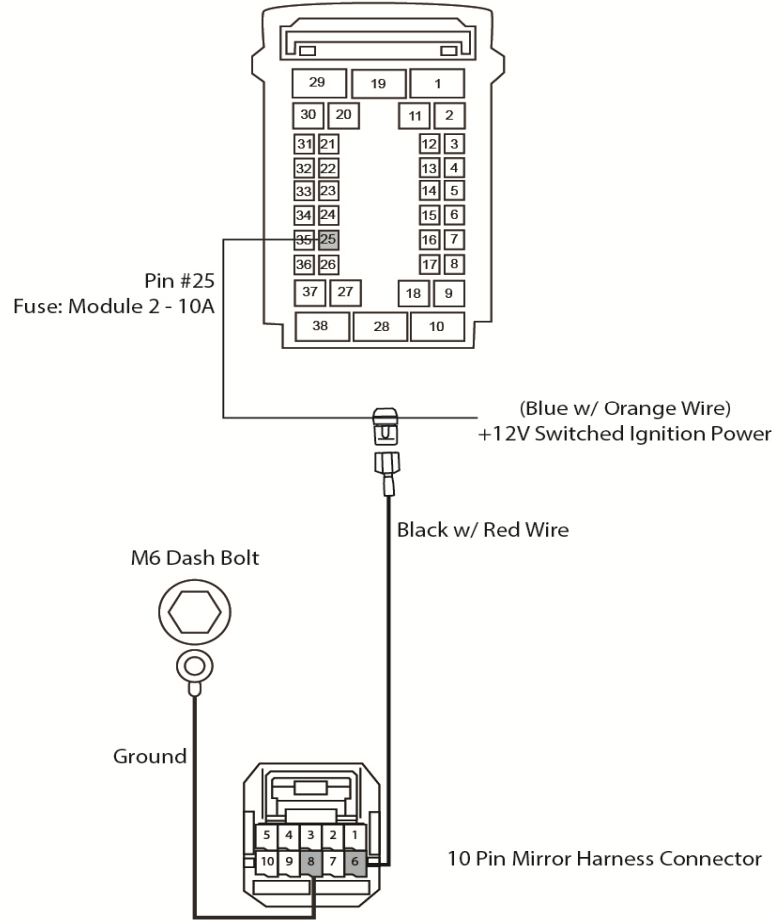

No	Gauge	Color	Function	Circuit	Fuse
1					
2					
3					
4					
5					
6	22	BLK w/ RED	IG (switched power)	O/S Mirror	Module 2 - 10A
7					
8	22	BLK	GND		
9					
10					