

# Genuine Accessories



Vehicle Model: Multiple

Model Year Multiple

Part No. S1F05 AK000

Language English

Rev. Date 12/17/2018

Accessory: Sport Pedals (A/T)

Difficulty: ( B )

**Note:** Difficulty stated above reflects the minimum level of expertise required to install the accessory:

- (A) Customer
- (B) Dealer Technician
- (C) Master Technician or Specialist

### Electronic Installation Instructions



If this is a printed copy of the installation instructions, ensure you have the latest revision by scanning the QR code or by entering the website address listed below before beginning installation. Use the latest revision date as noted by "Rev. Date" above.

[www.hyundaiaccessories.com/admin\\_media\\_uploads/installationSheets/s1f05\\_ak000.pdf](http://www.hyundaiaccessories.com/admin_media_uploads/installationSheets/s1f05_ak000.pdf)

### Instructional Symbols / Definitions

	Denotes warnings that may lead to serious physical injury or vehicle damage		Denotes quality processes to be checked prior to moving to the next step	Denotes personal protective equipment (PPEs) that may be required for a step. Examples of safety equipment icons noted below:	
	Denotes cautions to be taken to avoid physical injury or electronic component damage		Denotes specific tools that are necessary to complete a step		
	Denotes cautions to be taken to avoid vehicle and component damage	<b>N O T E</b>	Denotes important information to be reviewed during the step		
				Glasses	Gloves
				Mask	Hearing Protection

### Basic Required Tools

Ratchet	10mm Deep Well Socket	Flat Head Screwdriver	Torque Wrench	Extension

### Part Weight (Gross)

<b>1.10</b>	lbs
<b>0.50</b>	kg

All dealers must determine if the weight they have added in the form of all options or accessories, when added to the weight of all Port/Dealer installed options or accessories, exceeds the lesser of 1.5% of GVWR or 100 lbs. If the additional weight does exceed the lesser of the indicated thresholds, a "Load Carrying Capacity Reduced" label must be installed. A black, fine-point, indelible marker must be used to write by hand onto the label, the reduced carrying capacity in kilograms or pounds, which is the total weight of all added options and accessories.

**Load Label Part Number: NP070 - 09003**

### Notes to the installer:

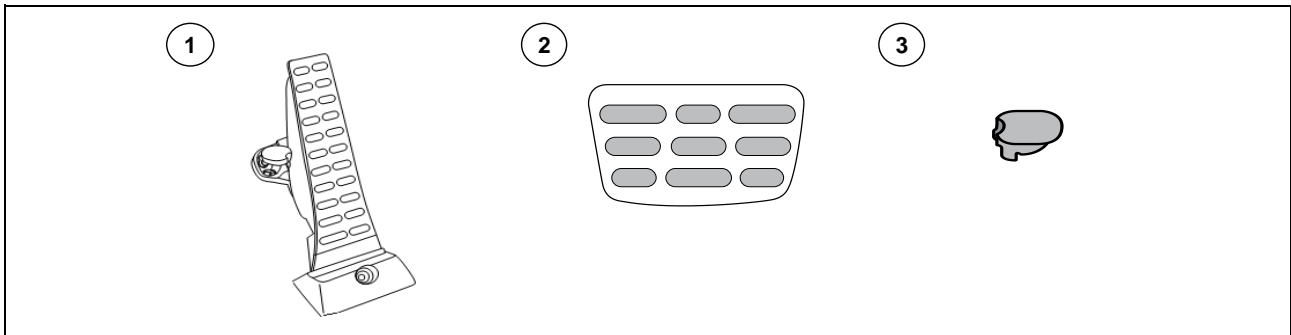

- 1) Read the entire Installation Instructions prior to beginning the installation of the part.
- 2) Make sure the vehicle is completely clean and dry in the area(s) the part is to be installed.
- 3) Ensure the vehicle is properly protected in the area(s) that the accessory is to be installed.
- 4) NEVER place tools on painted surfaces, seating surfaces, dash pad, console or floor carpet/mats.
- 5) Always wear appropriate personal protective equipment, including gloves, safety glasses, etc., when required.

### Kit Overview





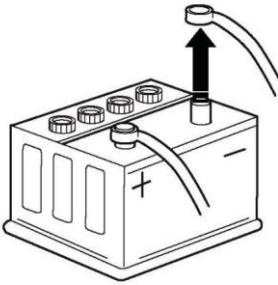

No.	Qty	Description
1	1	Accelerator Pedal Module
2	1	Brake Pedal Pad
3	1	Cap - Accelerator

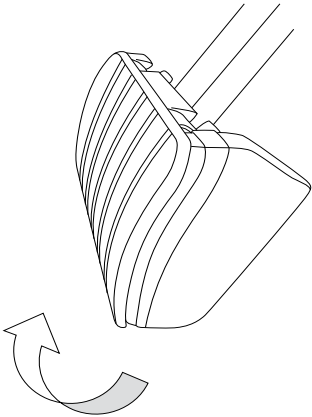
# Genuine Accessories

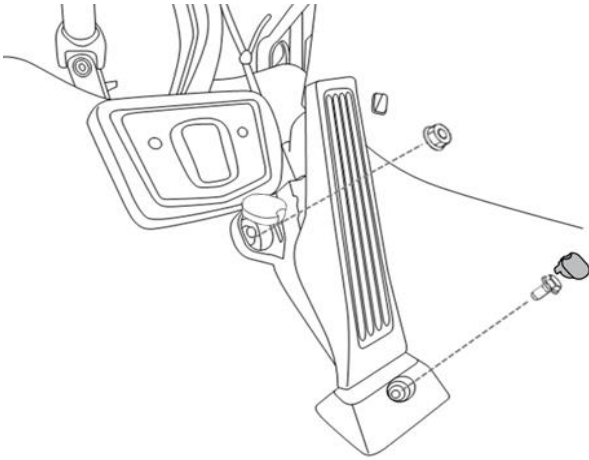

1		10mm Deep Well Socket and Ratchet
		
N O T E	<p>A. Open hood.                  B. Remove the Negative (-) Battery Terminal Cover, if applicable.                  C. Disconnect and isolate vehicle's Negative (-) Battery Cable.</p>	
 <p><b>WARNING! Shock Hazard. Do not touch vehicle's negative battery terminal to vehicle's positive battery terminal. Serious injury and damage to the vehicle may occur.</b></p>		

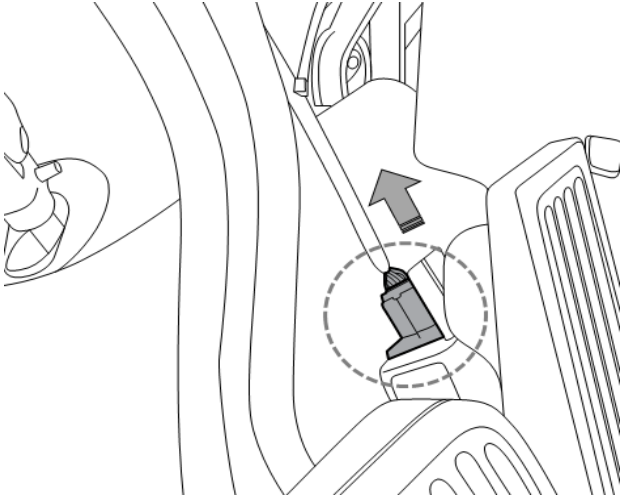
2		
		
N O T E	<p>A. Detach the Rubber Pad from the Brake Pedal by pulling the right and left edges of the Rubber Pad away from the Brake Pedal as shown.                  B. Discard Rubber Pad.</p>	

3		Flat Head Screwdriver, Ratchet, Extension and 10mm Socket
		
N O T E	<p>A. Open the upper cap and remove the lower cap from the Accelerator Pedal using a Flat Head Screwdriver.                  B. Discard the lower cap.                  C. Remove a bolt from the Accelerator Pedal.                  D. Remove a nut from the Accelerator Pedal.                  E. Save the bolt and nut for reinstallation.</p>	

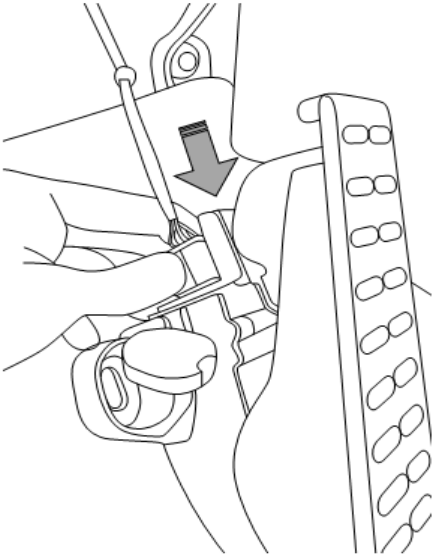

4		
		
N O T E	<p>A. Disconnect the Electrical Connector from the Accelerator Pedal; press the Side Release Tab, and pull the Connector up and away from the Accelerator Pedal.                  B. Discard the Accelerator Pedal.</p>	
 <p><b>Be careful not to pull on the Wire Harness when disconnecting the Electrical Connector to avoid damage.</b></p>		

## Genuine Accessories

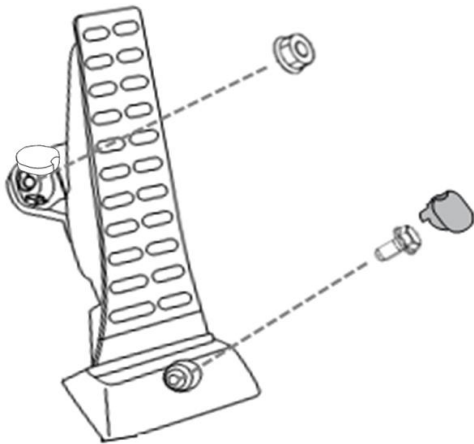
5		
		
N O T E	<p>A. Connect the Electrical Connector to the provided Accessory Accelerator Pedal.</p>	
	<p>Make sure the Electrical Connector makes an audible 'click' noise to confirm that it is fully connected to the Accessory Accelerator Pedal.</p>	

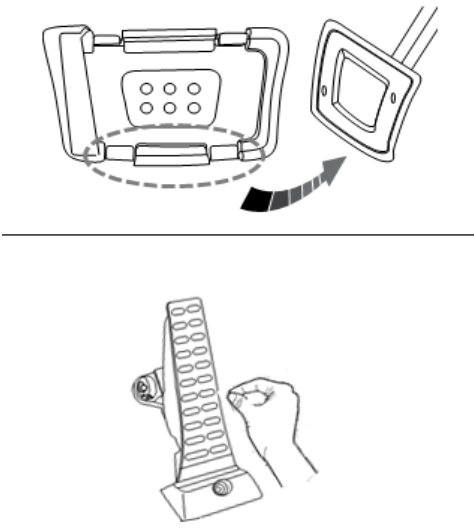

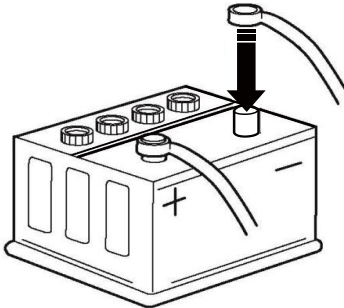

6		Ratchet, Extension, 10mm Socket and Torque Wrench
		
<p>Torque: 12.8 ~ 15.7 N.m (1.3 ~ 1.6 kgf.m, 9.4 ~ 11.6 lb-ft)</p>		
N O T E	<p>A. Reinstall the Accelerator Pedal bolt and nut.            B. Torque the bolt and nut to: <b>12.8-15.7 N.m (1.3-1.6 Kgf.m, 9.4-11.6 lb-ft)</b>.            C. Install the upper nut cap and the provided lower bolt cap as shown.</p>	

7		
		
N O T E	<p>A. Install the provided Accessory Brake Pedal Pad onto the Brake Pedal by engaging the Side Cover and then the Lower Hook onto the lower part of the Brake Pedal as shown.            B. By hand, apply pressure to the upper part of the Accessory Brake Pedal Pad until an audible 'click' is heard.            C. Remove the Protective Film from the Brake Pedal Pad and Accessory Pedal.</p>	

8		10mm Deep Well Socket, Ratchet and Torque Wrench
		
N O T E	<p>A. Reconnect the Negative (-) Battery Cable to the Battery and torque to: <b>4.0 ~ 6.0 N.m (0.4 ~ 0.6 kgf.m, 3.0 ~ 4.4 lb-ft)</b>.            B. Reinstall the Negative (-) Battery Terminal Cover, if applicable.            C. Close Hood.            D. Perform the Function Check on the following page.</p>	
 <p><b>WARNING! Shock Hazard. Do not touch vehicle's negative battery terminal to vehicle's positive battery terminal. Serious injury and damage to the vehicle may occur.</b></p>		

## Genuine Accessories

**Visual Check**

	Item to be Checked	Result	
	Do not leave the 10mm socket or ratchet in the engine compartment or on the battery after removing the negative battery cable.	10mm socket or ratchet is not in engine compartment or on battery.	
	Check that the accelerator pedal functions as intended. Start vehicle, keep gear selector in park, and apply gentle pressure to the accelerator pedal. DO NOT test drive vehicle.	Accessory accelerator pedal does not bind and operates as intended.	
	Make sure the connector is fully locked into the accessory accelerator pedal socket.	Electrical connector locked into accessory accelerator pedal socket.	
	Brake pedal pad is fully engaged and not loose.	Brake pedal pad properly installed.	