

Genuine Accessories



Vehicle Model: **Multiple**

Model Year Multiple
 Part No. S2F61 AU400
 Language English
 Rev. Date 4/12/2019

Accessory: **Ballmount Kit, Class 3**

Difficulty: (A)

Note: Difficulty stated above reflects the minimum level of expertise required to install the accessory:
 (A) Customer
 (B) Dealer Technician
 (C) Master Technician or Specialist

Electronic Installation Instructions

If this is a printed copy of the installation instructions, ensure you have the latest revision by scanning the QR code or by entering the website address listed below before beginning installation. Use the latest revision date as noted by "Rev. Date" above.

www.hyundaiaccessories.com/admin_media_uploads/installationSheets/s2f61_au400.pdf

Instructional Symbols / Definitions

<p>Denotes warnings that may lead to serious physical injury or vehicle damage</p>	<p>Denotes quality processes to be checked prior to moving to the next step</p>	<p>Denotes personal protective equipment (PPEs) that may be required for a step. Examples of safety equipment icons noted below:</p>
<p>Denotes cautions to be taken to avoid physical injury or electronic component damage</p>	<p>Denotes specific tools that are necessary to complete a step</p>	<div style="display: flex; justify-content: space-around;"> <div style="text-align: center;"> Glasses </div> <div style="text-align: center;"> Gloves </div> </div>
<p>Denotes cautions to be taken to avoid vehicle and component damage</p>	<div style="border: 1px solid black; padding: 2px; text-align: center; width: fit-content; margin: 0 auto;"> N O T E </div> <p>Denotes important information to be reviewed during the step</p>	<div style="display: flex; justify-content: space-around;"> <div style="text-align: center;"> Mask </div> <div style="text-align: center;"> Hearing Protection </div> </div>

Basic Required Tools

 <div style="border: 1px solid black; padding: 2px; width: fit-content; margin: 0 auto;">Adjustable Wrench</div>	 <div style="border: 1px solid black; padding: 2px; width: fit-content; margin: 0 auto;">38mm Socket</div>	 <div style="border: 1px solid black; padding: 2px; width: fit-content; margin: 0 auto;">Torque Wrench</div>
---	---	---

Part Weight (Gross)

3.90	lbs
1.77	kg

FMVSS 110 Compliance Information

All dealers must determine if the Net weight they have added in the form of all options or accessories, when added to the weight of all Port/Dealer Installed options or accessories, exceeds the lesser of 1.5% of GVWR or 100 lbs. If the additional weight does exceed the lesser of the indicated thresholds, a "Load Carrying Capacity Reduced" label must be installed. A black, fine-point, indelible marker must be used to write by hand onto the label, the reduced carrying capacity in kilograms or pounds, which is the total weight of all added options and accessories.
Load Label Part Number: NP070 - 09003

Notes to the installer:



- 1) Read the entire Installation Instructions prior to beginning the installation of the part.
- 2) Make sure the vehicle is completely clean and dry in the area(s) the part is to be installed.
- 3) Ensure the vehicle is properly protected in the area(s) that the accessory is to be installed.
- 4) NEVER place tools on painted surfaces, seating surfaces, dash pad, console or floor carpet/mats.
- 5) Always wear appropriate personal protective equipment, including gloves, safety glasses, etc., when required.

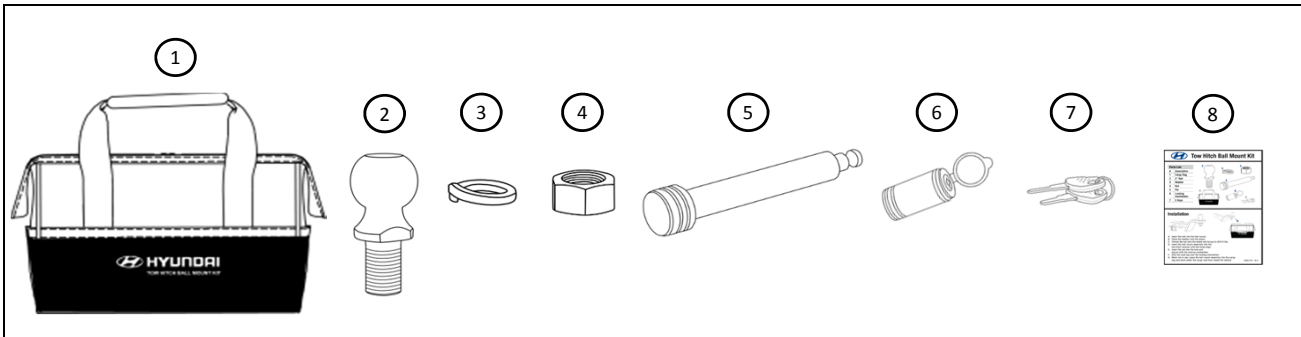

Kit Overview



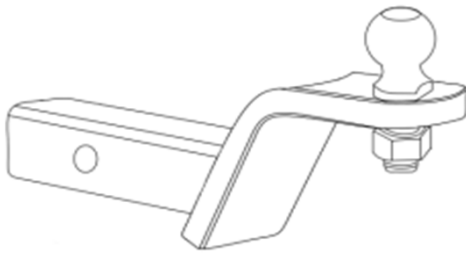

No.	Qty	Description	No.	Qty	Description
1	1	Cargo Bag	5	1	Pin
2	1	2" Ball	6	1	Locking Mechanism
3	1	Washer	7	2	Key
4	1	Nut	8	1	Information Card

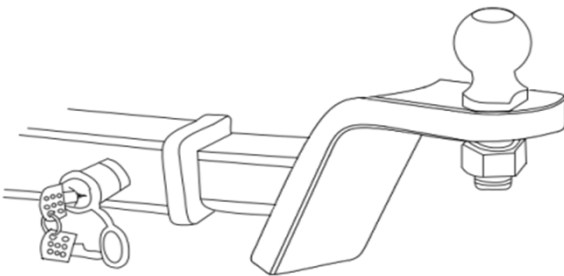
Genuine Accessories

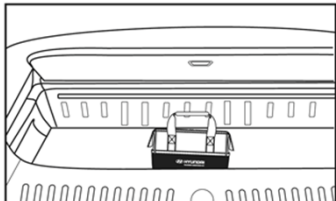
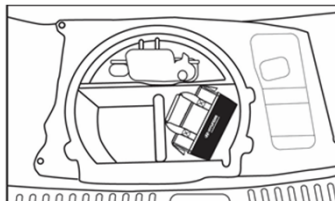
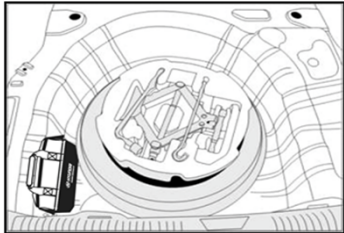
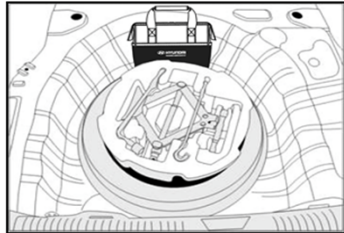
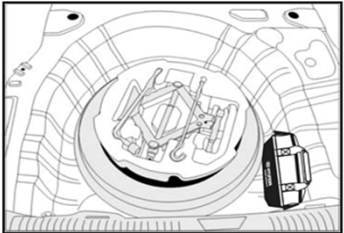

1		Adjustable Wrench, 38mm Socket and Torque Wrench
		
N O T E	<p>A. Insert the ball into the tow hitch ball mount. B. Place the washer onto the shank. C. Thread the nut onto the shank and torque nut to: 339 N.m (35 kgf.m, 250 ft-lbf).</p>	
	Ensure the nut is properly torqued.	

2		
		
N O T E	<p>A. Insert the ball mount assembly into the tow hitch receiver until the holes align. B. Insert the pin into the hole then secure with locking mechanism. C. Affix the dust cap over the locking mechanism.</p>	
	Ensure the locking mechanism is securely locked in place.	

3		
 		
  		
N O T E	<p>A. When not in use, place ball mount assembly into the cargo bag and store under the cargo load floor inside the vehicle; including sub-floor storage, spare tire well or tire mobility kit tray (if equipped). NOTE: Ensure all compartments, liners and covers can close without interference. B. Place the information card into the vehicle's glove box.</p>	
	Warning: In a sudden stop or collision, unsecured cargo could cause personal injury.	

Genuine Accessories

Visual Check

	Item to be Checked	Result	
	The nut is torqued to: 339 N.m (35 kgf.m, 250 ft-lbf)	Nut is torqued properly.	
	The locking mechanism is securely locked in place.	Locking mechanism is secure.	
	Confirm proper placement of the ball mount assembly/cargo bag.	The ball mount assembly/cargo bag is secure under cargo load floor.	

Care & Cleaning

Cleaning Instructions for:

Multiple

Ballmount Kit, Class 3

Spot clean with a damp cloth as needed (do not use chemical based cleaners).