

Genuine Accessories



Vehicle Model: **Palisade**

Model Year 2020-
 Part No. S8F61 AU000 (DIO)
S8F61 AU600 (PIO)
 Language English
 Rev. Date 10/17/2019

Accessory: **Tow Hitch**

Difficulty: (B)

Note: Difficulty stated above reflects the minimum level of expertise required to install the accessory:
 (A) Customer
 (B) Dealer Technician
 (C) Master Technician or Specialist

Electronic Installation Instructions











If this is a printed copy of the installation instructions, ensure you have the latest revision by scanning the QR code or by entering the website address listed below before beginning installation. Use the latest revision date as noted by "Rev. Date" above.

www.hyundaiaccessories.com/admin_media_uploads/installationSheets/s8f61_au000.pdf















Application Notes

The Installation Instructions below include steps for Tow Hitch Harness and Tow Hitch installation procedure. Pay special attention to the upper right corner symbol "  " of each step if not installing both accessories jointly.

Instructional Symbols / Definitions

 Denotes warnings that may lead to serious physical injury or vehicle damage	 Denotes quality processes to be checked prior to moving to the next step	Denotes personal protective equipment (PPEs) that may be required for a step. Examples of safety equipment icons noted below:
 Denotes cautions to be taken to avoid physical injury or electronic component damage	 Denotes specific tools that are necessary to complete a step	 Glasses
 Denotes cautions to be taken to avoid vehicle and component damage	N O T E Denotes important information to be reviewed during the step	 Gloves
		 Mask
		 Hearing Protection

Basic Required Tools

 Ratchet	 Extension	 3/8 Deep Well Socket	 11/16" Deep Well Socket	 10mm Deep Well Socket
 17mm Socket	 19mm Socket	 Exhaust Hanger Removal Tool	 Torque Wrench	 Speed Wrench
 Clip Removal Tool	 M10-1.25 Thread Chaser	 19mm Combination Wrench	 Yellow or White Paint Pen	 9mm Socket

Specialty Required Tools

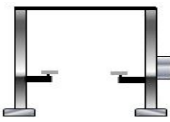
 Vehicle Lift
--

Part Weight (Gross)

45.46	lbs
20.62	kg

FMVSS 110 Compliance Information

All dealers must determine if the Net weight they have added in the form of all options or accessories, when added to the weight of all Port/Dealer Installed options or accessories, exceeds the lesser of 1.5% of GVWR or 100 lbs. If the additional weight does exceed the lesser of the indicated thresholds, a "Load Carrying Capacity Reduced" label must be installed. A black, fine-point, indelible marker must be used to write by hand onto the label, the reduced carrying capacity in kilograms or pounds, which is the total weight of all added options and accessories.
Load Label Part Number: NP070 - 09003

Notes to the installer:

- 1) Read the entire Installation Instructions prior to beginning the installation of this accessory.
- 2) Make sure the vehicle is completely clean and dry in the area(s) the part is to be installed.
- 3) Ensure the vehicle is properly protected in the area(s) that the accessory is to be installed.
- 4) NEVER place tools on painted surfaces, seating surfaces, dash pad, console or floor carpet/mats.
- 5) Always wear appropriate personal protective equipment, including gloves, safety glasses, etc., when required.
- 6) Roll down the driver's window and adjust the power seats (if applicable) prior to disconnecting battery power, if needed.
- 7) Record radio presets prior to disconnecting battery power, if needed.
- 8) Vehicle should be at room temperature.

Genuine Accessories

Kit Overview

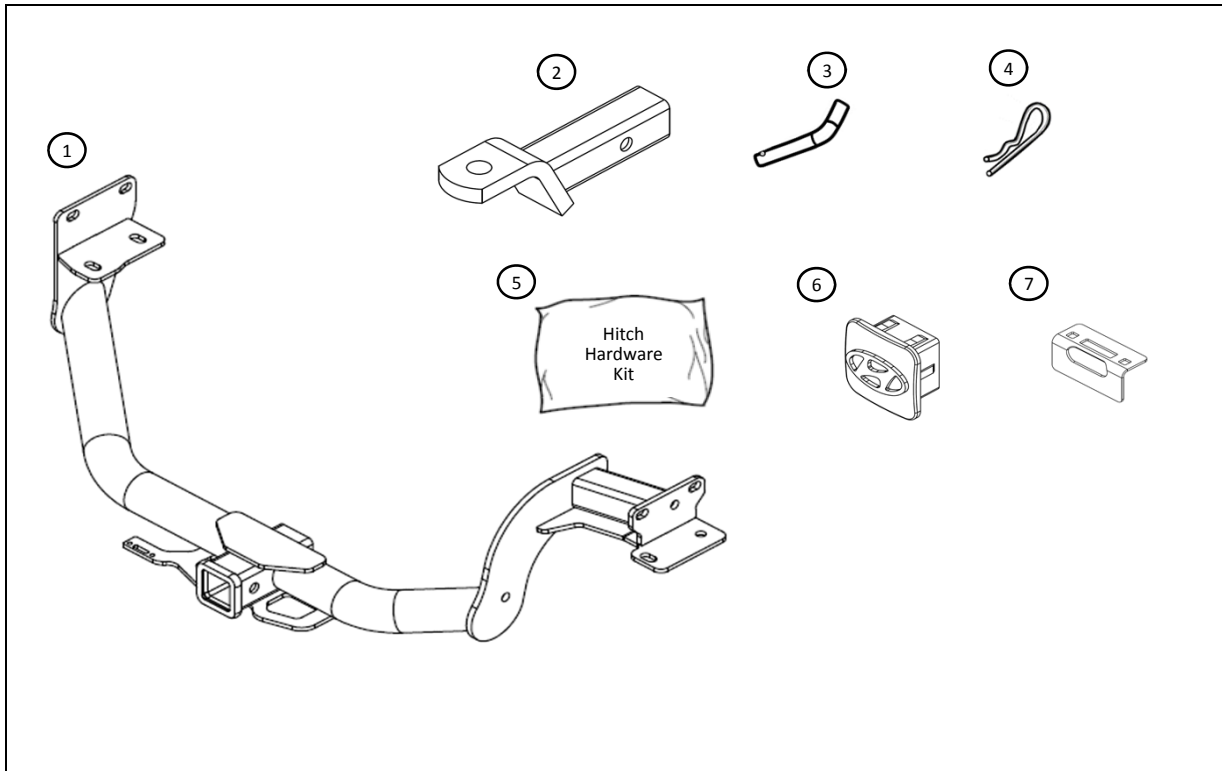

No.	Qty	Description	No.	Qty	Description	No.	Qty	Description
1	1	Hitch	4	1	Hitch Pin Clip	7	1	4-Flat Connector Bracket
2	1	Ball Mount	5	1	Hitch Hardware Kit			
3	1	Hitch Pin	6	1	Hitch Receiver Plug			

Hardware Overview

A		B		C		D		E	
2	M12x120 Bolt	4	M12 Toothed Washer	2	M12 Hex Nut	2	7/16" x 4.5" Special Bolt	2	7/16" Toothed Washer
F		G		H		H		H	
2	7/16" Hex Nut	4	M10x30 Bolt	4	M10 Toothed Washer	2	#10 x 1" Carriage Bolt	4	#10 Nylock Hex Nut





Follow instructions for proper placement of each component.



Hardware Total
28

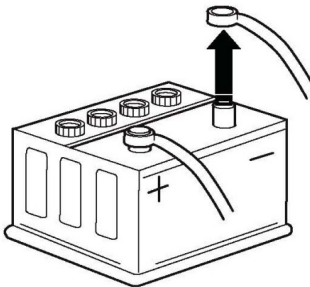

Radio Presets - record customer preset frequencies if disconnecting battery power

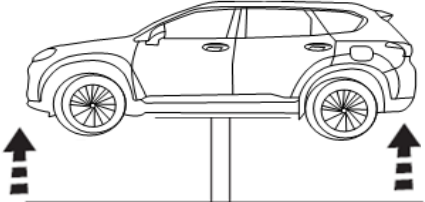

FM1 _____	FM2 _____	FM3 _____	FM4 _____	FM5 _____
FM6 _____	FM7 _____	FM8 _____	FM9 _____	FM10 _____
AM1 _____	AM2 _____	AM3 _____	AM4 _____	AM5 _____
SAT1 _____	SAT2 _____	SAT3 _____	SAT4 _____	SAT5 _____

Genuine Accessories

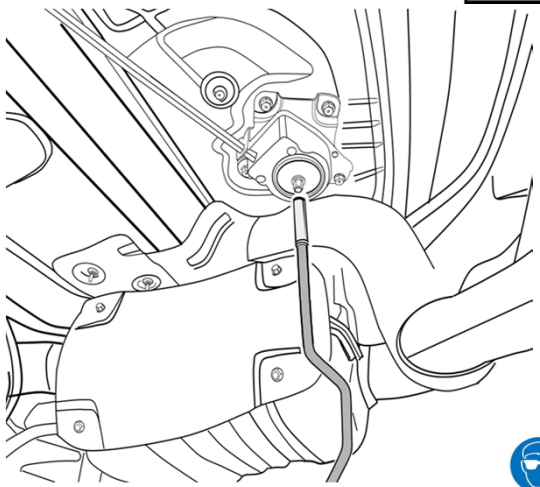

1		Ratchet, 10mm Deep Socket and Vehicle Lift
<div style="border: 1px solid black; padding: 2px; display: inline-block;">HITCH HARNESS</div>		
<p>Tow Hitch Harness Installation Procedure ONLY</p> 		
 		
N O T E	<p>A. Position the vehicle on a vehicle lift. B. Record any pre-set radio stations (if applicable). C. Open the vehicle's hood. D. Remove the Cap from Negative (-) Battery Cable, if applicable. E. Disconnect and isolate the vehicle's Negative (-) Battery Cable. F. Raise vehicle to desired working height to access the under body at the rear bumper.</p>	
 <p>Warning! Shock Hazard. Do not touch vehicle's negative battery cable to the vehicle's positive battery cable. Serious injury and damage to the vehicle may occur. WARNING: Comply with vehicle lift manufacture's instructions and safety when using the lift.</p>		

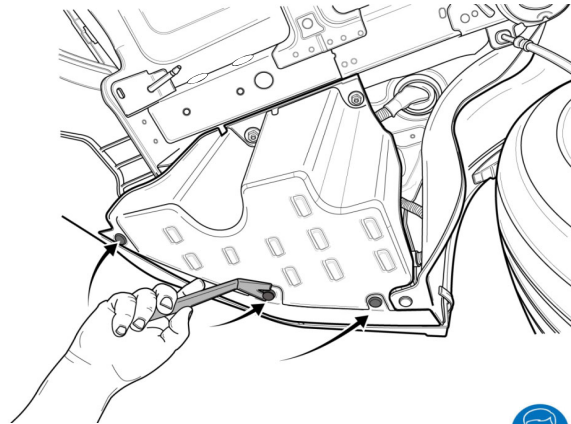

2		Vehicle Lift
<div style="border: 1px solid black; padding: 2px; display: inline-block;">HITCH HARNESS</div>		
<p>Tow Hitch Installation Procedure ONLY</p> 		
		
N O T E	<p>A. Position the vehicle on a vehicle lift. B. Raise vehicle to desired working height to access the under body at the rear bumper.</p>	
 <p>WARNING: Comply with vehicle lift manufacture's instructions and safety when using the lift.</p>		

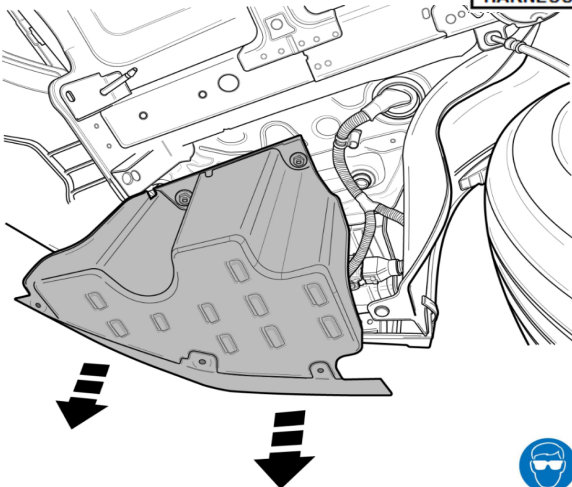

3		Speed Wrench and 9mm Socket
<div style="border: 1px solid black; padding: 2px; display: inline-block;">HITCH HARNESS</div>		
		
		
N O T E	<p>A. Using a speed wrench and 9mm socket, lower and remove the spare tire by loosening the spare tire carrier nut as shown. B. Store the spare tire in a safe location for reinstallation.</p>	

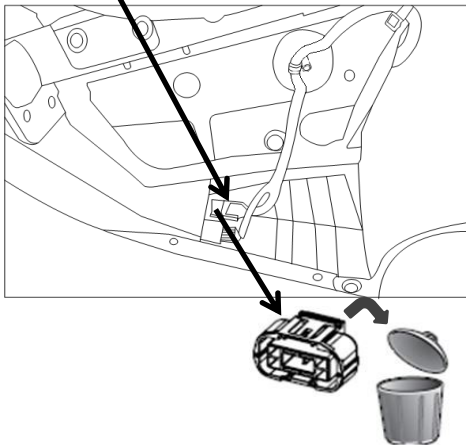

4		Clip Removal Tool
<div style="border: 1px solid black; padding: 2px; display: inline-block;">HITCH HARNESS</div>		
		
		
N O T E	<p>A. Using a clip removal tool, remove the three (3) lower plastic push clips on the driver side plastic cover. B. Store the three (3) plastic push clips in a safe location for reinstallation.</p>	

Genuine Accessories

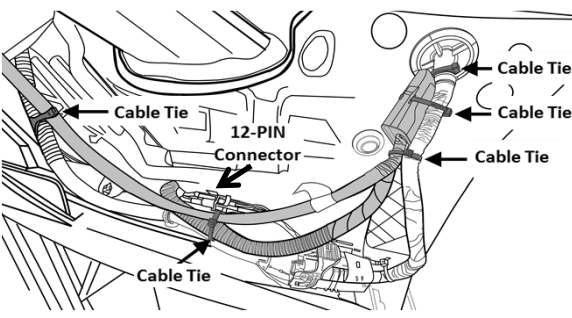
5		HITCH HARNESS
		
N O T E	<p>A. Dislodge and remove the driver side plastic cover panel by pulling straight down.</p> <p>B. Ensure the two (2) upper plastic clips detach with the side plastic cover panel. If necessary, remove the two (2) upper plastic clips by hand.</p> <p>C. Store the removed parts in a safe location for reinstallation.</p>	
		

6		HITCH HARNESS
<p>12-Pin Connector Mounting Location</p> 		
N O T E	<p>A. Locate the factory 12-Pin harness with connector protective cover on the driver's side rear quarter panel area.</p> <p>NOTE: If the factory 12-Pin harness with connector is taped to the large factory harness near the grommet, remove the tape and secure the 12-Pin connector to the inner bumper cover pre-existing mounting hole.</p> <p>B. Remove connector protective cover and discard.</p>	
		
 <p>CAUTION! Make sure connector is clean and free of any debris.</p>		

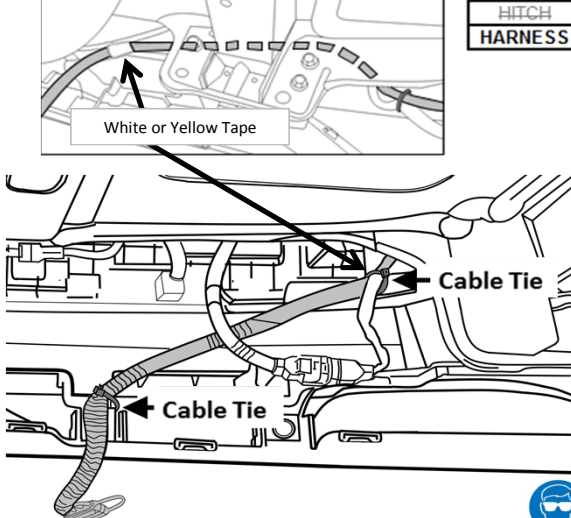
7	 Wire Cutters	HITCH HARNESS
		
N O T E	<p>A. Connect Tow Hitch Harness 12-Pin Connector to the vehicle factory connector as shown.</p> <p>B. Secure the module to the vehicle factory harness, as shown, by passing one (1) cable tie through the side tabs of the module, one (1) cable tie through the hole at the end of the module and one (1) cable tie at the base of the module. Trim excess cable tie material.</p> <p>C. Using two (2) cable ties, secure the Tow Hitch Harnesses to the vehicle factory harnesses as shown but do NOT fully tighten the cable ties at this time.</p>	
		
 <p>Ensure the Connector is fully engaged and locked in place.</p>		

8	 Wire Cutters	HITCH HARNESS
		
N O T E	<p>A. Route the Tow Hitch Harness over the bumper beam behind the rear bumper as shown.</p> <p>B. Note the location of the White Tape surrounding the Tow Hitch Harness.</p> <p>C. Using one (1) cable tie, secure the Tow Hitch Harness to vehicle factory harness at the <u>White or Yellow Tape</u> location as shown.</p> <p>D. Using one (1) cable tie, secure the Tow Hitch Harness to the bumper bracket as shown.</p> <p>E. Take up any harness slack and tighten the two (2) loose cable ties from step 7. Trim excess cable tie material.</p>	
		
 <p>Ensure the upper cable tie is placed at the White or Yellow Tape location on the Tow Hitch Harness.</p>		

Genuine Accessories

9 Exhaust Hanger Removal Tool

NOTE

A. Using an exhaust hanger removal tool, dislodge the two (2) rearmost exhaust hangers from the rubber holders.

Ensure the exhaust is at room temperature.

10

NOTE

A. Pass the two (2) M12 bolts through the frame on the driver's side to ensure that there are no blockages in the channels.
 B. Repeat the process on the passenger's side using the two (2) 7/16" special bolts to ensure there are no blockages in the channels.

11 M10-1.25 Thread Chaser

NOTE

A. Before installing the hitch, confirm there is no debris or weld spatter in the chassis rail weld nuts. Confirm the four (4) M10 Bolts thread into the four (4) mounting holes of the frame rails.
 B. If needed, use an M10-1.25 thread chaser to clean out the weld nuts.

Do not cross thread the M10-1.25" weld nut threads when chasing them.

12

NOTE

A. Preassemble one (1) M12 bolt with one (1) M12 toothed washer for driver side as shown above. Have a 7/16" special bolt for passenger side ready.
NOTE: Make sure the 'toothed side' of washer is installed facing the hitch.
 B. Raise hitch under vehicle starting with raising the hitch over the muffler on the passenger side.
 C. Insert one (1) M12 bolt with one (1) M12 toothed washer on the driver side, as shown above.

Genuine Accessories

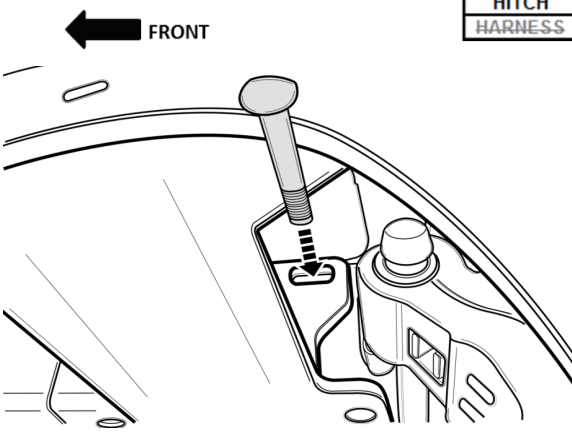
13		HITCH HARNESS
		
N O T E	<p>A. Insert one (1) 7/16" special bolt, flat side up, through rear mounting hole in the vertical plate as shown above. Bolt should go fully through the hitch and frame on the passenger side.</p> <p>NOTE: Bolt must be inserted on the inside of the chassis rails. This will hold the hitch in position.</p>	

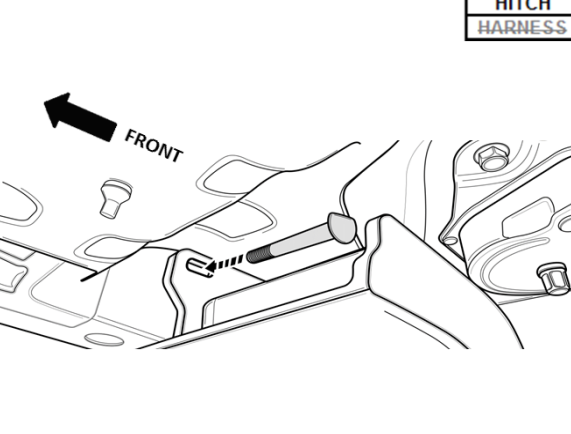

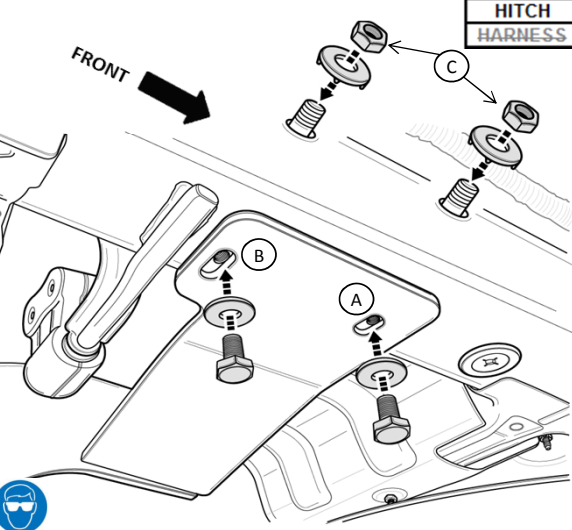
14		HITCH HARNESS
		
N O T E	<p>A. Insert one (1) 7/16" special bolt, flat side up, through front mounting hole in the vertical plate as shown above. Bolt should go fully through the hitch and frame on the passenger side.</p>	

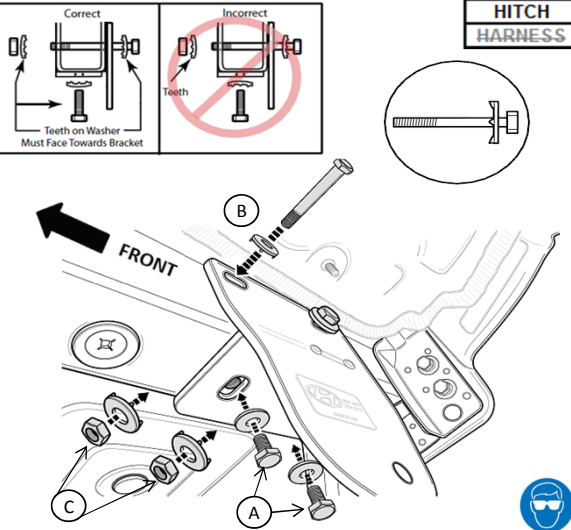
15		HITCH HARNESS
		
N O T E	<p>A. Starting on the passenger's side forward Tow Hitch horizontal hole, hand tighten one (1) M10 bolt with one (1) M10 toothed washer into vehicle's weld nut.</p> <p>B. Hand tighten one (1) M10 bolt with one (1) M10 toothed washer into rear vehicle's weld nut.</p> <p>NOTE: Make sure the 'toothed side' on each washer is installed facing the hitch.</p> <p>C. Hand tighten one (1) 7/16" hex nut and one (1) 7/16" toothed washer onto the two (2) bolts as shown.</p> <p>NOTE: Make sure the "toothed side" of the washer is installed against the frame.</p>	

16		HITCH HARNESS
		
N O T E	<p>A. Hand tighten one (1) M10 bolt with one (1) M10 toothed washer into the tow (2) vehicle's weld nuts on the driver's side.</p> <p>B. Install one (1) M12 bolt and one (1) M12 toothed washer into remaining upper attachment point on driver's side.</p> <p>NOTE: Make sure the 'toothed side' on the washer is installed facing the hitch.</p> <p>C. Install one (1) M12 hex nut & one (1) toothed washer onto two (2) M12 bolts on driver's side & hand tighten.</p> <p>NOTE: Make sure the "toothed side" of the washers are installed against the frame.</p>	

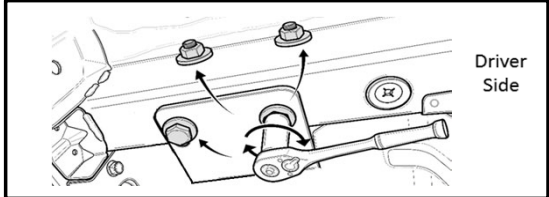
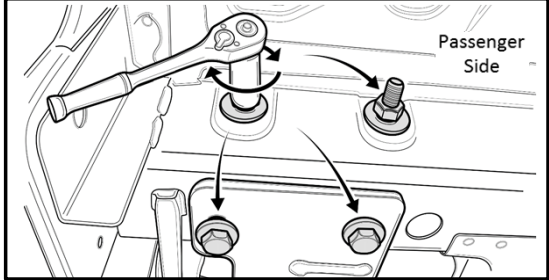
Genuine Accessories

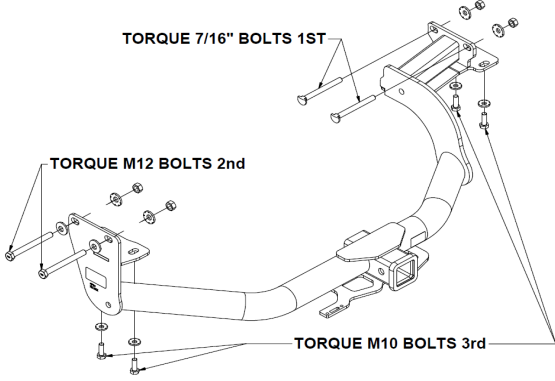
17		Ratchet, Extension, 17mm Socket, 19mm Socket, 19mm Combination Wrench and 11/16" Deep Socket
HITCH HARNESS		
 <p style="text-align: right;">Driver Side</p>		
 <p style="text-align: right;">Passenger Side</p>		
NOTE	<p>A. Tighten the four (4) M10 Bolts until tow hitch makes contact with vehicle's frame. Do NOT torque bolts at this time.</p> <p>B. Tighten the two (2) 7/16" special bolts until nut and washer become snug to vehicle's frame.</p> <p>C. Tighten the two (2) M12 Bolts until nut and washer become snug to vehicle's frame.</p>	

18		Torque Wrench, Extension, 17mm Socket, 19mm Socket, 19mm Combination Wrench, 11/16" Deep Socket & Yellow or White Paint Pen
HITCH HARNESS		
 <p style="text-align: center;">TORQUE 7/16" BOLTS 1ST</p> <p style="text-align: center;">TORQUE M12 BOLTS 2nd</p> <p style="text-align: center;">TORQUE M10 BOLTS 3rd</p>		
<p>Bolt Torque Sequence:</p> <ol style="list-style-type: none"> 1) Torque 7/16" bolts to 80 N·m (8.2 kgf·m, 59 lbf·ft) 2) Torque M12 bolts to 107 N·m (10.9 kgf·m, 79 lbf·ft) 3) Torque M10 bolts to 62 N·m (6.4 kgf·m, 46 lbf·ft) 		
NOTE	<p>A. Using an extension, 17mm socket, 19mm socket, 19mm combination wrench, 11/16" deep socket and torque wrench, tighten and torque all of the nuts and bolts following the bolt torque sequence shown above.</p> <p>B. Repeat torque sequence to ensure bolts are tightened properly.</p> <p>C. Use a yellow or white paint pen to mark a line on top of each bolt head.</p> <p>NOTE: The paint line should go across the bolt head and onto the hitch or vehicle.</p>	
 <p>Do NOT over-torque the hardware.</p>		

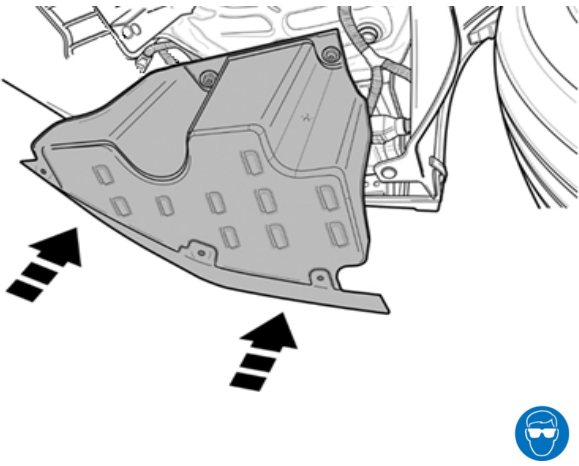

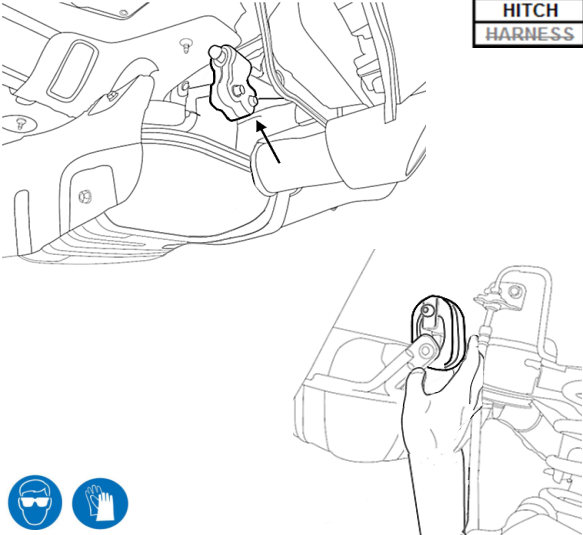
19		
HITCH HARNESS		
		
NOTE	<p>A. Reinstall the driver side plastic cover panel by aligning the upper plastic clips and pushing straight up.</p> <p>B. Reinstall the three (3) lower plastic push clips.</p>	

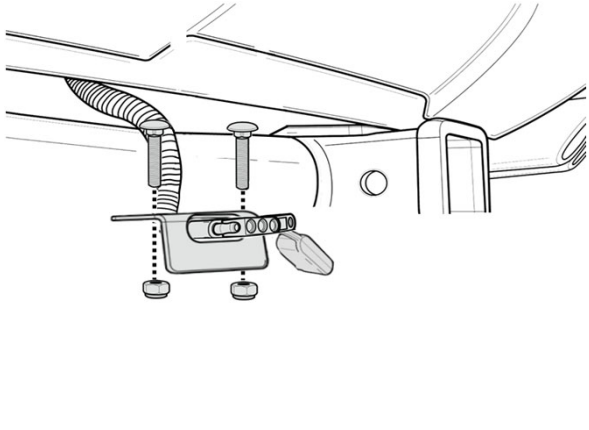

20		
HITCH HARNESS		
		
NOTE	<p>A. Reinstall the two (2) rubber muffler mounts back onto their brackets.</p> <p>B. Ensure they are fully seated back into their original position.</p>	

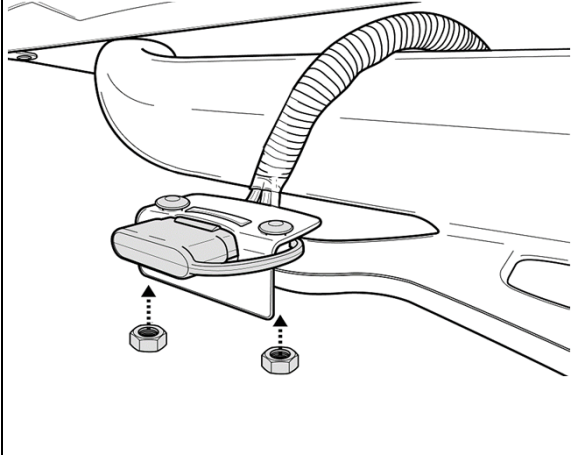
Genuine Accessories

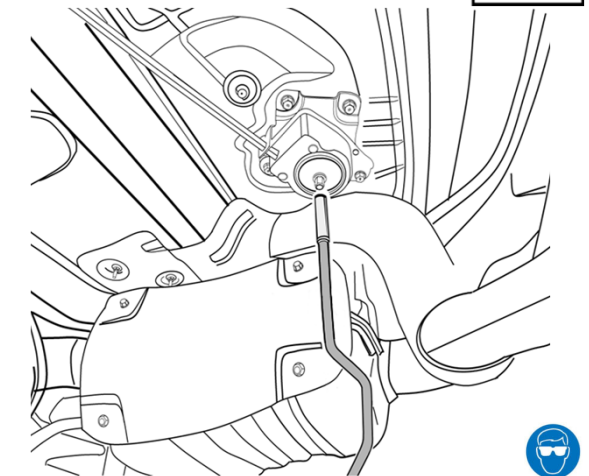

21		Ratchet, and 3/8" Socket	HITCH HARNESS
			
N O T E	<p>A. Insert the Tow Hitch Harness 4-Flat Connector through back side of the 4-Flat Connector Bracket as shown.</p> <p>B. Place two (2) #10 carriage bolts through the top of the 4-Flat Connector Bracket and thread two (2) #10 nylock hex nuts as shown.</p> <p>C. Make sure the Ground Pin is positioned towards the Driver Side of the vehicle.</p>		

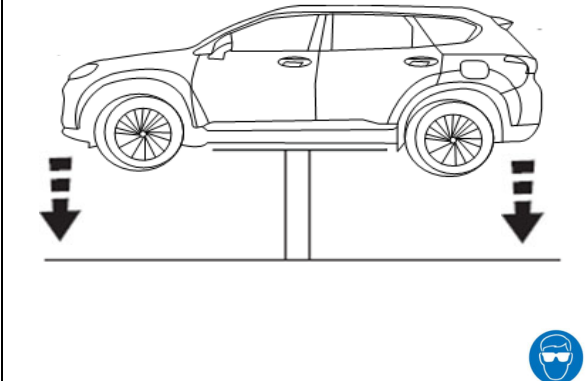
22		Ratchet, Torque Wrench and 3/8" Socket	HITCH HARNESS
			
N O T E	<p>A. Place the 4-Flat connector and bracket assembly through the hitch bracket so the larger forward detent is located in rectangular slot in the hitch plate.</p> <p>B. Thread two (2) #10 nylock hex nuts to secure the connector bracket assembly to the hitch bracket and torque to: 3.38 N·m (0.35 kgf·m, 30.0 lbf·in). NOTE: Make sure bracket is in the orientation shown above and aligned squarely on the hitch connector bracket.</p> <p>C. Secure the Dust Cover over the 4-Flat connector.</p>		

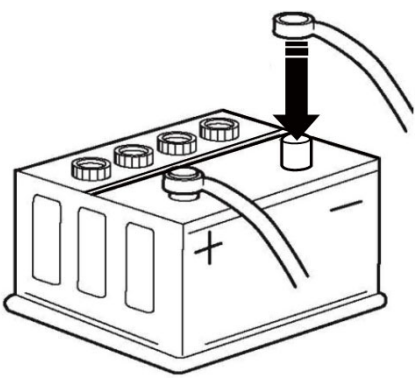

23		Speed Wrench and 9mm Socket	HITCH HARNESS
			
N O T E	<p>A. Using the speed wrench and 9mm socket, raise the spare tire back into its original position.</p> <p>B. Visually confirm everything is reinstalled back onto the vehicle.</p>		
	Confirm spare tire is secured and seated properly.		

24		Vehicle Lift	HITCH HARNESS
			
N O T E	<p>A. Lower the vehicle.</p>		
	WARNING: Comply with vehicle lift manufacturer's instructions and safety when using the lift.		

Genuine Accessories

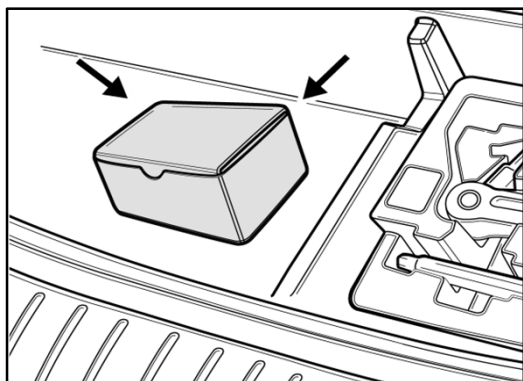
25		Ratchet, 10mm Deep Socket and Torque Wrench
<div style="border: 1px solid black; padding: 2px; display: inline-block;">HITCH HARNESS</div>		
		
		
NOTE	<p>A. Reconnect the Vehicle's Negative (-) Battery Cable, torque to: 5.0 ~ 6.0 N.m (0.5 ~ 0.6 kgf.m, 45 ~ 52 lb-in).</p> <p>B. Reinstall the Cap from Negative (-) Battery Cable, if applicable.</p> <p>C. Close the vehicle's hood.</p> <p>D. Reprogram any pre-set radio stations (if applicable).</p>	





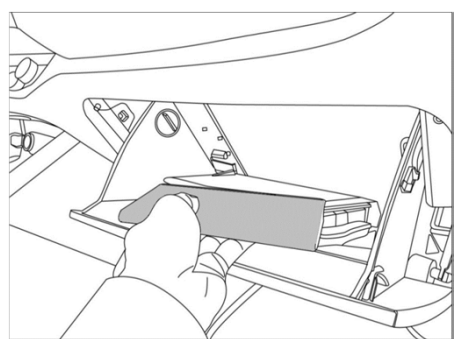



26		
<div style="border: 1px solid black; padding: 2px; display: inline-block;">HITCH HARNESS</div>		
		
NOTE	<p>A. Open tailgate.</p> <p>B. Place box containing the ball mount, hitch pin & clip under cargo floorboard in the cargo storage compartment.</p> <p>C. Close tailgate.</p>	

27		12V Tester or Volt Meter
<div style="border: 1px solid black; padding: 2px; display: inline-block;">HITCH HARNESS</div>		
		
NOTE	<p>A. Perform Function Check at the end of the Tow Hitch Harness installation instructions with a 12V Tester or Volt Meter.</p>	

28		
<div style="border: 1px solid black; padding: 2px; display: inline-block;">HITCH HARNESS</div>		
		
NOTE	<p>A. Place the Tow Hitch Harness Caution Card into the Glove Box.</p>	

Genuine Accessories

Visual Check

Item to be Checked		Result	
	Make sure four (4) M10 x 30 bolts are torqued to: 68 N·m (6.9 kgf·m, 50 lbf·ft)	The four (4) M10 x 30 bolts are torqued to: 68 N·m (6.9 kgf·m, 50 lbf·ft)	
	Make sure two (2) M12 x 120 bolts are torqued to: 107 Nm (10.9 kgf-m, 79 lbf-ft).	The two (2) M12 x 120 bolts are torqued to: 107 Nm (10.9 kgf-m, 79 lbf-ft).	
	Make sure two (2) 7/16" x 4.5" special bolts are torqued to: 80 Nm (8.2 kgf-m, 59 lbf-ft).	The Two (2) 7/16" x 4.5" special bolts are torqued to: 80 Nm (8.2 kgf-m, 59 lbf-ft).	
	Make sure all eight (8) bolts and surrounding tow hitch / frame surfaces are marked using a paint pen.	All eight (8) bolts and surrounding tow hitch / frame surfaces have paint line marks.	
	Make sure the muffler hangers are reinstalled properly.	Muffler hangers are reinstalled properly.	
	Make sure the driver side plastic panel is reinstalled properly.	The driver side plastic panel is reinstalled properly.	
	Make sure the spare tire is reinstalled and seated properly.	The spare tire is reinstalled and seated properly.	
	Make sure the ball mount box is placed under cargo floorboard in the cargo storage compartment.	Ball mount box is placed under cargo floorboard in the cargo storage compartment.	
	Make sure the 4-flat connector is mounted in hitch electrical bracket and dust cap is secured over connector.	The 4-flat connector is mounted in hitch electrical bracket and dust cap is secured over connector.	